

Digital Audio

DVC Digital Voice Command

Installation, Programming and Operations Manual



Fire Alarm & Emergency Communication System Limitations

While a life safety system may lower insurance rates, it is not a substitute for life and property insurance!

An automatic fire alarm system—typically made up of smoke detectors, heat detectors, manual pull stations, audible warning devices, and a fire alarm control panel (FACP) with remote notification capability—can provide early warning of a developing fire. Such a system, however, does not assure protection against property damage or loss of life resulting from a fire.

An emergency communication system—typically made up of an automatic fire alarm system (as described above) and a life safety communication system that may include an autonomous control unit (ACU), local operating console (LOC), voice communication, and other various interoperable communication methods—can broadcast a mass notification message. Such a system, however, does not assure protection against property damage or loss of life resulting from a fire or life safety event.

The Manufacturer recommends that smoke and/or heat detectors be located throughout a protected premises following the recommendations of the current edition of the National Fire Protection Association Standard 72 (NFPA 72), manufacturer's recommendations, State and local codes, and the recommendations contained in the Guide for Proper Use of System Smoke Detectors, which is made available at no charge to all installing dealers. This document can be found at <http://www.systemsensor.com/appguides/>. A study by the Federal Emergency Management Agency (an agency of the United States government) indicated that smoke detectors may not go off in as many as 35% of all fires. While fire alarm systems are designed to provide early warning against fire, they do not guarantee warning or protection against fire. A fire alarm system may not provide timely or adequate warning, or simply may not function, for a variety of reasons:

Smoke detectors may not sense fire where smoke cannot reach the detectors such as in chimneys, in or behind walls, on roofs, or on the other side of closed doors. Smoke detectors also may not sense a fire on another level or floor of a building. A second-floor detector, for example, may not sense a first-floor or basement fire.

Particles of combustion or "smoke" from a developing fire may not reach the sensing chambers of smoke detectors because:

- Barriers such as closed or partially closed doors, walls, chimneys, even wet or humid areas may inhibit particle or smoke flow.
- Smoke particles may become "cold," stratify, and not reach the ceiling or upper walls where detectors are located.
- Smoke particles may be blown away from detectors by air outlets, such as air conditioning vents.
- Smoke particles may be drawn into air returns before reaching the detector.

The amount of "smoke" present may be insufficient to alarm smoke detectors. Smoke detectors are designed to alarm at various levels of smoke density. If such density levels are not created by a developing fire at the location of detectors, the detectors will not go into alarm.

Smoke detectors, even when working properly, have sensing limitations. Detectors that have photoelectronic sensing chambers tend to detect smoldering fires better than flaming fires, which have little visible smoke. Detectors that have ionizing-type sensing chambers tend to detect fast-flaming fires better than smoldering fires.

Because fires develop in different ways and are often unpredictable in their growth, neither type of detector is necessarily best and a given type of detector may not provide adequate warning of a fire.

Smoke detectors cannot be expected to provide adequate warning of fires caused by arson, children playing with matches (especially in bedrooms), smoking in bed, and violent explosions (caused by escaping gas, improper storage of flammable materials, etc.).

Heat detectors do not sense particles of combustion and alarm only when heat on their sensors increases at a predetermined rate or reaches a predetermined level. Rate-of-rise heat detectors may be subject to reduced sensitivity over time. For this reason, the rate-of-rise feature of each detector should be tested at least once per year by a qualified fire protection specialist. Heat detectors are designed to protect property, not life.

IMPORTANT! Smoke detectors must be installed in the same room as the control panel and in rooms used by the system for the connection of alarm transmission wiring, communications, signaling, and/or power. If detectors are not so located, a developing fire may damage the alarm system, compromising its ability to report a fire.

Audible warning devices such as bells, horns, strobes, speakers and displays may not alert people if these devices are located on the other side of closed or partly open doors or are located on another floor of a building. Any warning device may fail to alert people with a disability or those who have recently consumed drugs, alcohol, or medication. Please note that:

- An emergency communication system may take priority over a fire alarm system in the event of a life safety emergency.
- Voice messaging systems must be designed to meet intelligibility requirements as defined by NFPA, local codes, and Authorities Having Jurisdiction (AHJ).
- Language and instructional requirements must be clearly disseminated on any local displays.
- Strobes can, under certain circumstances, cause seizures in people with conditions such as epilepsy.
- Studies have shown that certain people, even when they hear a fire alarm signal, do not respond to or comprehend the meaning of the signal. Audible devices, such as horns and bells, can have different tonal patterns and frequencies. It is the property owner's responsibility to conduct fire drills and other training exercises to make people aware of fire alarm signals and instruct them on the proper reaction to alarm signals.
- In rare instances, the sounding of a warning device can cause temporary or permanent hearing loss.

A life safety system will not operate without any electrical power. If AC power fails, the system will operate from standby batteries only for a specified time and only if the batteries have been properly maintained and replaced regularly.

Equipment used in the system may not be technically compatible with the control panel. It is essential to use only equipment listed for service with your control panel.

Telephone lines needed to transmit alarm signals from a premises to a central monitoring station may be out of service or temporarily disabled. For added protection against telephone line failure, backup radio transmission systems are recommended.

The most common cause of life safety system malfunction is inadequate maintenance. To keep the entire life safety system in excellent working order, ongoing maintenance is required per the manufacturer's recommendations, and UL and NFPA standards. At a minimum, the requirements of NFPA 72 shall be followed. Environments with large amounts of dust, dirt, or high air velocity require more frequent maintenance. A maintenance agreement should be arranged through the local manufacturer's representative. Maintenance should be scheduled as required by National and/or local fire codes and should be performed by authorized professional life safety system installers only. Adequate written records of all inspections should be kept.

Limit-D2-2016

Installation Precautions

Adherence to the following will aid in problem-free installation with long-term reliability:

WARNING - Several different sources of power can be connected to the fire alarm control panel. Disconnect all sources of power before servicing. Control unit and associated equipment may be damaged by removing and/or inserting cards, modules, or interconnecting cables while the unit is energized. Do not attempt to install, service, or operate this unit until manuals are read and understood.

CAUTION - System Re-acceptance Test after Software Changes: To ensure proper system operation, this product must be tested in accordance with NFPA 72 after any programming operation or change in site-specific software. Re-acceptance testing is required after any change, addition or deletion of system components, or after any modification, repair or adjustment to system hardware or wiring. All components, circuits, system operations, or software functions known to be affected by a change must be 100% tested. In addition, to ensure that other operations are not inadvertently affected, at least 10% of initiating devices that are not directly affected by the change, up to a maximum of 50 devices, must also be tested and proper system operation verified.

This system meets NFPA requirements for operation at 0-49° C/ 32-120° F and at a relative humidity 93% ± 2% RH (non-condensing) at 32°C ± 2°C (90°F ± 3°F). However, the useful life of the system's standby batteries and the electronic components may be adversely affected by extreme temperature ranges and humidity. Therefore, it is recommended that this system and its peripherals be installed in an environment with a normal room temperature of 15-27° C/60-80° F.

Verify that wire sizes are adequate for all initiating and indicating device loops. Most devices cannot tolerate more than a 10% I.R. drop from the specified device voltage.

Like all solid state electronic devices, this system may operate erratically or can be damaged when subjected to lightning induced transients. Although no system is completely immune from lightning transients and interference, proper grounding will reduce susceptibility. Overhead or outside aerial wiring is not recommended, due to an increased susceptibility to nearby lightning strikes. Consult with the Technical Services Department if any problems are anticipated or encountered.

Disconnect AC power and batteries prior to removing or inserting circuit boards. Failure to do so can damage circuits.

Remove all electronic assemblies prior to any drilling, filing, reaming, or punching of the enclosure. When possible, make all cable entries from the sides or rear. Before making modifications, verify that they will not interfere with battery, transformer, or printed circuit board location.

Do not tighten screw terminals more than 9 in-lbs. Over-tightening may damage threads, resulting in reduced terminal contact pressure and difficulty with screw terminal removal.

This system contains static-sensitive components. Always ground yourself with a proper wrist strap before handling any circuits so that static charges are removed from the body. Use static suppressive packaging to protect electronic assemblies removed from the unit.

Units with a touchscreen display should be cleaned with a dry, clean, lint free/microfiber cloth. If additional cleaning is required, apply a small amount of Isopropyl alcohol to the cloth and wipe clean. Do not use detergents, solvents, or water for cleaning. Do not spray liquid directly onto the display.

Follow the instructions in the installation, operating, and programming manuals. These instructions must be followed to avoid damage to the control panel and associated equipment. FACP operation and reliability depend upon proper installation.

Precau-D2-11-2017

FCC Warning

WARNING: This equipment generates, uses, and can radiate radio frequency energy and if not installed and used in accordance with the instruction manual may cause interference to radio communications. It has been tested and found to comply with the limits for class A computing devices pursuant to Subpart B of Part 15 of FCC Rules, which is designed to provide reasonable protection against such interference when devices are operated in a commercial environment. Operation of this equipment in a residential area is likely to cause interference, in which case the user will be required to correct the interference at his or her own expense.

Canadian Requirements

This digital apparatus does not exceed the Class A limits for radiation noise emissions from digital apparatus set out in the Radio Interference Regulations of the Canadian Department of Communications.

Le present appareil numerique n'emet pas de bruits radio-electriques depassant les limites applicables aux appareils numeriques de la classe A prescrites dans le Reglement sur le brouillage radioelectrique edicte par le ministere des Communications du Canada.

HARSH™, NIS™, NOTI-FIRE-NET™, and eVance™ are all trademarks; and Acclimate® Plus™, FlashScan®, FAAST Fire Alarm Aspiration Sensing Technology®, Honeywell®, Intelligent FAAST®, NOTIFIER®, ONYX®, ONYXWorks®, SWIFT®, VeriFire®, and VIEW® are all registered trademarks of Honeywell International Inc. Microsoft® and Windows® are registered trademarks of the Microsoft Corporation. Chrome™ and Google™ are trademarks of Google Inc.

©2019 by Honeywell International Inc. All rights reserved. Unauthorized use of this document is strictly prohibited.

Software Downloads

In order to supply the latest features and functionality in fire alarm and life safety technology to our customers, we make frequent upgrades to the embedded software in our products. To ensure that you are installing and programming the latest features, we strongly recommend that you download the most current version of software for each product prior to commissioning any system. Contact Technical Support with any questions about software and the appropriate version for a specific application.

Documentation Feedback

Your feedback helps us keep our documentation up-to-date and accurate. If you have any comments or suggestions about our online Help or printed manuals, you can email us.

Please include the following information:

- Product name and version number (if applicable)
- Printed manual or online Help
- Topic Title (for online Help)
- Page number (for printed manual)
- Brief description of content you think should be improved or corrected
- Your suggestion for how to correct/improve documentation

Send email messages to:

FireSystems.TechPubs@honeywell.com

Please note this email address is for documentation feedback only. If you have any technical issues, please contact Technical Services.

Table of Contents

Section 3: General Information	9
3.1: Standards and Other Documents	9
NFPA Standards	9
Underwriter Laboratories.....	9
Underwriters Laboratories of Canada (ULC)	9
Other	9
3.2: UL 864 9th and 10th Edition	9
3.2.1: Products Subject to AHJ Approval.....	9
Programming Features Subject to AHJ Approval	9
Supplemental Documentation.....	10
Cautions and Warnings.....	11
Section 1: DVC Digital Voice Command	12
1.1: DVC Overview	12
1.1.1: About This Manual.....	12
1.2: Description.....	13
1.2.1: Features.....	15
1.2.2: Options.....	15
DVC-AO.....	15
DVC-KD.....	15
DS-FM, DS-SFM, DS-RFM.....	15
1.2.3: Specifications	16
24VDC Power - TB1	16
Digital Audio Ports A and B - TB2, TB3	16
Auxiliary Input A (AUX A) - TB 4	16
Auxiliary Input B (AUX B) - TB14.....	16
Remote Microphone Interface - TB9.....	16
Push-to-talk Interface - TB10	16
Alarm Bus - TB12.....	16
FFT Riser - TB13.....	16
Optional DVC-AO Analog Audio Output Circuits - TB5, TB6, TB7 and TB8.....	17
1.3: DVC Board Layout.....	17
1.3.1: Connections	17
1.3.2: Switches and Indicators	18
Switch Functions.....	18
Indicators	19
1.4: Options.....	20
1.4.1: DVC-AO Analog Output Board Layout.....	20
1.4.2: DVC-KD Keypad	20
1.4.3: Fiber Option Boards	20
Specifications.....	21
Section 2: DVC Installation	23
2.1: Overview.....	23
2.1.1: Chassis	23
2.1.2: Doors and Dress Panels	23
Doors for CA-2 Installations.....	23
Doors for CA-1 Installations.....	23
Dress Panels for CA-2 Installations	23
Dress Panels for CA-1 Installations.....	23
2.2: Prepare for Installation	24
2.3: Installation Checklist	25
2.4: Cabinet.....	25
2.5: Mount DVC Option Boards.....	25
2.5.1: Installing Fiber Option Modules.....	26
2.5.2: DVC-AO Analog Output Board	26
2.5.3: DVC-KD Keypad	27
2.6: Mount a Network Communications Module in a CA-1 or CA-2 Chassis	28
2.7: Mount a DVC Board in a CA-1 or CA-2 Chassis	28
2.8: Using a CFFT-1 with the CA-1 Chassis	29
2.9: Move the Chassis for Wiring Access	29
2.9.1: CA-1	29

2.9.2: CA-2	30
2.10: Wiring	30
2.10.1: DVC Board to 24V Power	30
2.10.2: Alarm Bus	31
2.10.3: Digital Audio Ports A and B.....	32
Wire Terminals	32
Fiber Connections (Using Fiber Option Modules).....	32
2.10.4: FFT Connectivity.....	34
FFT Riser (TB13)	34
2.10.5: Auxiliary Inputs A and B.....	34
Auxiliary Input A.....	34
Auxiliary Input B.....	35
2.10.6: Network Connection (NUP) Ports	35
2.10.7: USB Ports	36
2.10.8: Push-to-Talk Indicator	36
2.10.9: RM-1 Remote Microphone Interface.....	36
2.10.10: MIC-1 Local Microphone Interface.....	37
2.10.11: TELH-1 Local Phone Interface	37
2.10.12: Analog Audio Outputs (DVC-AO).....	37
2.10.13: Wiring Fault Testing.....	38
2.10.14: UL Power-limited (Class 2) Wiring Requirements	39
2.11: Replacement of NVRAM Memory-Backup Battery	39
Section 3: DVC Configuration and Programming	40
3.1: Setting the Configuration Switches	40
3.1.1: Piezo (Switch 5).....	40
3.1.2: 4WIRE (Switch 8)	40
3.2: Programming	40
3.2.1: Overview.....	40
3.2.2: Programming in VeriFire Tools.....	40
DVC Special Function Zones	40
VeriFire Tools Utilities	41
3.2.3: Special Applications	41
Mass Notification Systems	41
Releasing Systems	41
Live Voice Instructions.....	41
3.2.4: VeriFire Tools Programming Interface	41
3.3: General Settings Branch	43
3.3.1: General Settings Tab.....	44
General Settings Tab, Column 1	44
General Settings Tab, Column 2.....	45
General Settings Tab, Column 3.....	46
3.3.2: General Settings Branch, Program Settings Tab	46
All Call Mapping, Special Paging Functions.....	46
3.4: KD Mapping DVC-KD.....	48
3.5: DVC General Zones	50
3.6: DAL Mapping.....	50
3.6.1: Overview.....	50
3.6.2: DAA/DAX/DAA2 Amplifier Programming Options.....	51
DAA-5025 PCA	51
DAA-5025 PCB	51
DAA-5070 PCA	51
DAA-5070 PCB.....	51
DAA-7525 PCB.....	51
DAA2-5025 PCA	51
DAA2-5070 PCA.....	52
DAA2-7525 PCA.....	52
DAX-3525 PCA	52
DAX-3570 PCA.....	52
DAX-5025 PCA.....	52
DAX-5070 PCA.....	52
3.6.3: DAA/DAX/DAA2 Amplifier Field Definitions	52

Basic DAL Device Settings (Top Half of DAL Mapping Screen).....	52
General Settings Tab (Bottom Half of DAL Mapping Screen).....	52
Speaker Circuits Tab (Bottom Half of DAL Mapping Screen).....	53
3.6.4: DS-DB Programming Options.....	53
DS-DB PCA.....	53
3.6.5: DS-DB Field Definitions.....	54
DS-DB General Settings Tab.....	54
DS-DB Low-Level Output Tab.....	54
DS-DB Speaker Circuit Settings Tab.....	55
DS-DB Groups Tab.....	55
3.6.6: DVC-RPU Programming Options.....	55
RPU-PCC.....	55
3.6.7: DVC-RPU Field Definitions.....	55
General Settings Tab.....	55
RPU-KD Tab.....	55
3.7: Audio Message Programming Overview.....	57
3.8: Audio Settings Branch.....	57
3.8.1: Message Segments.....	57
3.8.2: Message Sequences.....	58
3.9: DVC Inputs Branch.....	59
3.10: PAM Settings Branch.....	62
3.10.1: Prioritized Audio Matrix (PAM) Programming Overview.....	62
Addressing a PAM Point.....	62
Activating a PAM Point.....	62
3.10.2: Network Paging.....	63
3.10.3: Message Overrides.....	65
3.10.4: Programming a PAM point.....	65
3.11: Logic Equations Branch.....	66
3.11.1: Logic Equation Data-Entry Grid.....	66
3.11.2: Logic Equation Builder.....	66
3.11.3: Edit and Save Changes (Logic Equation Commands).....	67
3.11.4: Functions (Logic Equation Operators).....	67
3.11.5: Points (Logic Equation Operands).....	67
3.11.6: DAL Device Alarm Bus Activation Using Logic Equation Programming.....	68
3.12: Special Function Zones.....	68
3.13: Program Validation.....	69
3.14: Reports.....	69
Section 4: DVC Operation.....	70
4.1: Using the DVC-KD Keypad on the DVC.....	70
4.1.1: Pre-defined Buttons/Indicators.....	70
Buttons When MN Mode = None.....	70
Buttons When MN Mode = ACU, LOC, or CCS.....	71
4.1.2: LED Indicators.....	71
4.1.3: 24 User-programmable Buttons.....	72
4.2: Paging.....	72
4.2.1: MIC-1 Microphone Paging.....	72
4.2.2: TELH-1 Telephone Paging.....	72
4.2.3: RM-1 Remote Microphone Paging.....	72
Configured with Annunciator.....	72
Configured with Keypad.....	73
4.2.4: AUXA/AUXB Paging.....	73
4.2.5: FFT Paging.....	73
4.3: Display and Control Center (DCC).....	73
4.4: Trouble Messages.....	73
Non-displayed Events.....	73
Read Status.....	73
Appendix A: DAL Earth Fault Detection.....	74
Appendix B: FFT Communication.....	76
B.1: FFT Paging.....	76
B.2: DVC Firefighter's Telephone Network Communication.....	76

B.2.1: FFT Communication Local to DVC Node.....	76
B.2.2: Point-to-point FFT Communication over Noti•Fire•Net (FFT-NFN)	77
Appendix C: Trouble Messages	81
Appendix D: Audio Groups	86
D.1: Overview.....	86
D.2: Examples.....	86
D.2.1: One Amplifier Per Group	86
D.2.2: Multiple Amplifiers Per Group.....	88
D.3: Rules	89
Appendix E: DVC MN Modes	90
E.1: DVC-KD Installation	90
E.2: Programming.....	90
Glossary	91
Index	94
Section 1: Operating Conditions.....	97
Section 2: To Page from the DVC	97
Section 3: To Enable FFT Communication and Paging.....	97
Section 4: LED Indicators.....	97
Section 5: User-defined Buttons	97
Section 6: Lamp Test	97
Section 7: Periodic Testing and Maintenance	97
Section 7: Before Testing:	97
Section 7: After Testing:.....	97
Section 8: Local Service Representative:	97

Section 3: General Information

3.1 Standards and Other Documents

The Digital Voice Command and Digital Audio Amplifiers Series comply with the following standards:

- NFPA 72 National Fire Alarm Code
- Underwriter Laboratories Standard UL 864
- Underwriter Laboratories of Canada (ULC) ULC-S527-11 Standard of Control Units for Fire Alarm Systems
- Part 15 Class A conducted and radiated emissions as required by the FCC

The installer should be familiar with the following documents and standards:

NFPA Standards

NFPA 72 National Fire Alarm Code

Underwriter Laboratories

UL 464 Audible Signaling Appliances
 UL 864 Standard for Control Unit and Accessories for Fire Alarm Systems
 UL 1481 Power Supplies for Fire Protective Signaling Systems
 UL 1638 Visual Signaling Appliances - Private-Mode Emergency and General Utility Signaling
 UL 1711 Amplifiers for Fire Protective Signaling Systems
 UL 60950 Safety of Information Technology Equipment
 UL 1971 Signaling Devices for the Hearing Impaired
 UL 2572 Mass Notification Systems

Underwriters Laboratories of Canada (ULC)

ULC-S527-11 Standard of Control Units for Fire Alarm Systems

Other

FCC Part 15 Class A Conducted and Radiated Emissions

3.2 UL 864 9th and 10th Edition

- Per the UL Continuing Certification Program, UL 864 9th edition fire alarm control equipment will retain certification after the rollout of UL 10th edition (12/2/2018).
- Installations of UL 864 10th Edition certified equipment are permitted to use UL864 9th Edition certified equipment when approved by the local Authority Having Jurisdiction (AHJ).

For product compliance, refer to the UL/ULC listing cards located on the UL online certification directory.

<http://iq.ulprospector.com>

3.2.1 Products Subject to AHJ Approval

The following products have not received UL 864 9th or 10th Edition certification and may only be used in retrofit applications. Operation of the DVC with products not tested for UL 864 9th or 10th Edition has not been evaluated and may not comply with NFPA 72 and/or the latest edition of UL 864. These applications will require the approval of the local Authority Having Jurisdiction (AHJ).

NFS-640 Fire Alarm Control Panel
 NCA Network Control Annunciator

NFS-3030 Fire Alarm Control Panel
 AMG -1

Programming Features Subject to AHJ Approval

This product incorporates field-programmable software. The features and/or options listed below must be approved by the local AHJ.

This product incorporates field-programmable software. In order for the product to comply with the requirements in the Standard for Control Units and Accessories for Fire Alarm Systems, UL 864, ULC-S527, certain programming features or options must be limited to specific values or not used at all as indicated below.			
Program Feature or Option	Permitted in UL 864/ULC-S527? (Y/N)	Possible Settings	Settings Permitted in UL 864/ULC-S527
IP downloads over a local area network (LAN) or the Internet (Wide Area Network - WAN)	No	Yes No	No

Supplemental Documentation

The table below provides a list of documents referenced in this manual, as well as documents for selected other compatible devices.

VeriFire Tools Help File and installation document	VeriFire Tools Help File, 51690
Mass Notification System Manual	LS10063-000NF-E
DAA2/DAX Devices Manual	53265
DS-DB Manual	53622
DVC-RPU UL Listing Document	50107424-001
DVC-RPU Manual	50107425-001
Wire Guide Addendum for Digital Audio Loops	52916ADD
DVC-AO Audio Option Board Installation Document	52728
DVC-KD Keypad Product Installation Document	52709
Heat Dissipation Calculations Document for Cabinets with Digital Audio Products	53645
CA-1 Chassis Product Installation Document	52474
CA-2 Chassis Product Installation Document	52455
CFFT-1 Chassis for Firefighter's Telephone Product Installation Document	53289
CMIC-1 Chassis Product Installation Document	52476
NFS2-3030 Listing Document	LS10006-051NF-E
NFS2-640 Listing Document	52741LD
NFS-320 Listing Document	52745LD
AMPS-24 Manual	51907
ACPS-610 Addressable Power Supply Manual	53018
NFS-640 Installation, Programming, Operations Manuals	51332, 51333, 51334
NFS-3030 Installation, Programming, Operations Manual	51330, 51345, 51344
NCA Network Control Annunciator Manual	51482
NCA-2 Network Control Annunciator Manual	52482
ONYXWorks Workstation: ONYXWORKS-WS Listing Document	LS10050-003NF-E
ONYXWorks NOTIFY IP Manual	53620
Noti-Fire-Net Manual	51584
High-Speed Noti-Fire-Net Manual	54013
NCM Installation Document	51533
HS-NCM High Speed Network Communications Module Installation Document	54014
SLC Wiring Manual	51253
DAL Devices Product Information Sheet	52410
AA Series Audio Amplifier Manual	52526
ACS Annunciator Manual	15842
AFAWS Automatic Fire Alarm Warden Station	50705
FTM-1 Firephone Control Module	156-1391
ACT-4 Audio Coupling Transformer	53431
ACT-25 Audio Coupling Transformer	53432
ACT-70 Audio Coupling Transformer	53240
RM-1 Series Remote Microphones	51138
RPJ-1 Remote Paging Jack	15058
FPJ Firefighter's Phone Jack	15510
CAB-4 Series Cabinets Installation Instructions	15330
EQ-CAB Series Installation Instructions	53412
Audio Fiber Links Document	52230
RSM-1A Residential Silence Module	156-006
AIM-1A Audible Isolation Module	156-006
CIM-2A/CSM-1A Isolator and Silencing Modules	156-2200

Table 3.1 Related Documentation Table

Cautions and Warnings

This manual contains cautions and warnings to alert the reader as follows:



CAUTION: CAUTION SUMMARY DESCRIPTION

INFORMATION ABOUT PROCEDURES THAT COULD CAUSE PROGRAMMING ERRORS, RUNTIME ERRORS, OR EQUIPMENT DAMAGE.



WARNING: WARNING SUMMARY DESCRIPTION

INDICATES INFORMATION ABOUT PROCEDURES THAT COULD CAUSE IRREVERSIBLE DAMAGE TO THE CONTROL PANEL, IRREVERSIBLE LOSS OF PROGRAMMING DATA, OR PERSONAL INJURY.

Section 1: DVC Digital Voice Command

1.1 DVC Overview

1.1.1 About This Manual

■ DVC Board

In this manual, the term DVC refers to the PCC version of the DVC-EM. This model accommodates both wire and fiber digital audio port connections of all previous DVC models. It will work with audio software release DVC 5.0 and higher.

The board is easily distinguishable from former DVC-EM models: there are pin connectors and corresponding screw holes in the spaces for fiber modules. The board is also marked “DVC-EMPCC”.

■ UL 2572

As of audio software release 7.0, the digital audio system is compliant with UL’s Mass Notification Standard UL 2572. Programming is covered in Chapter 3 of this manual. For a full explanation of how the digital audio system fits into a UL 2572 application, refer to the Mass Notification System Manual, LS10063-000NF-E.

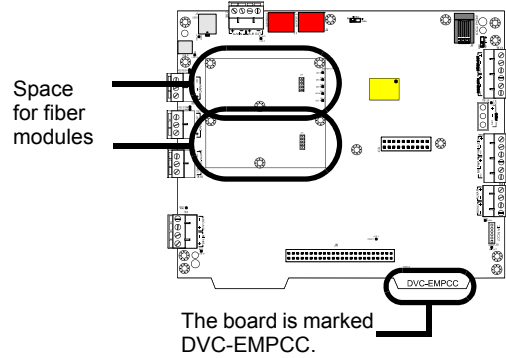

Figure 1.1 DVC-EM, PCC Version

■ UL 864 Low-Frequency Sounder Compliance

This product complies with the requirements for a low frequency sounder (520Hz) as specified in UL 464 when used as part of a system with the following amplifiers, communication devices, audio files, and speakers.

Amplifiers

Amplifier Combination	Description
DAA2-5025 with or without a BDA-25V	DAA2-5025: 120VAC 25VRMS digital audio amplifier BDA-25V: 25VRMS backup digital audio amplifier
DAA2-5070 with or without a BDA-70V	DAA2-5070: 120VAC 70VRMS digital audio amplifier BDA-70V: 70VRMS backup digital audio amplifier
DAA2-7525 with or without a BDA-25V	DAA2-7525: 120VAC 25VRMS digital audio amplifier BDA-25V: 25VRMS backup digital audio amplifier
DAX-5025 with or without a BDA-25V	DAX-5025: 120VAC 25VRMS digital audio amplifier BDA-25V: 25VRMS backup digital audio amplifier
DAX-5070 with or without a BDA-70V	DAX-5070: 120VAC 70VRMS digital audio amplifier BDA-70V: 70VRMS backup digital audio amplifier
DAX-3525 with or without a BDA-25V	DAX-3525: 120VAC 25VRMS digital audio amplifier BDA-25V: 25VRMS backup digital audio amplifier
DAX-3570 with or without a BDA-70V	DAX-3570: 120VAC 70VRMS digital audio amplifier BDA-70V: 70VRMS backup digital audio amplifier
DS-DB with a DS-AMP with or without a DS-XF70V	DS-DB: digital series distribution board DS-AMP: digital series amplifier DS-XF70: step-up transformer required for 70V operation
DS-DB with a DS-BDA with or without a DS-XF70V	DS-DB: digital series distribution board DS-BDA: backup digital series audio amplifier DS-XF70: step-up transformer required for 70V operation

Communication Devices

Model Number	Description
DS-FM	Multi-mode fiber option module
DS-SFM	Single-mode fiber option module
DS-RFM	Multi-mode fiber option module

Audio Files

Name	Description
520Hz temporal 3 HQ.wav	Temporal Horn pattern with 520Hz for High Quality systems
520Hz temporal 3 SQ.wav	Temporal Horn pattern with 520Hz for Standard Quality systems

Speakers:

For a complete list of speakers that can be used in a Digital Voice Command system with the above specifications, refer to the current version of the Device Compatibility document, p/n 15378.

1.2 Description

The DVC is a multi-featured audio processor with digital audio functionality that operates as an event-driven audio message generator and router. It is designed for use with the DAA, DAA2, and DAX Series digital audio amplifiers, the DS-DB digital series distribution boards, and the DVC-RPU, in a single panel or networked environment. The DVC has two wire digital audio ports, each of which may be converted to a fiber port using a fiber option module. With the addition of the optional DVC-AO board, the DVC may also be used as an analog audio source in retrofit analog audio applications. (See Figure 1.2.)

The NFS2-640 and NFS2-3030 may be directly connected to the DVC for single panel applications. An NCA-2 is required with the NFS2-640 when a DAL (Digital Audio Loop) is part of the configuration. An NCA-2 is *not* required with the NFS2-640 when there is no DAL. Refer to Figure 1.2 for illustrations of single panel configurations.

Network configurations require an NCA-2 or NFS2-3030 programmed to display DVC troubles, and will support all Network Control-by-Event (CCBE) from the following panels: NFS2-640, NFS-640, NFS2-3030, NFS-3030, and NFS-320. A network workstation can be used to display troubles.

When used with the optional DVC-KD keypad and an NCA-2 or NFS2-3030, the DVC becomes the key component of an audio command center, accepting live paging from several sources and providing the ability to direct the paging to appropriate pre-programmed speaker zones in the system.

The DVC stores up to 32 minutes of standard quality audio (11.025 KHz sampling rate, 8 bit μ -law, mono), or 4 minutes of high quality audio (44.1 KHz sampling rate, 16 bit PCM, mono).



NOTE: The terms DAA, DAA2, DAX, DS-AMP and BDA are used in this manual to refer to all respective models of each type of amplifier. Individual part numbers are used only when it is necessary to distinguish features or functions that differ. Refer to the appropriate manual for individual model descriptions.

Figure 1.2 gives simplified overview illustrations of typical applications for the DVC and its Digital Audio Loop (DAL).



NOTE: Wire and fiber versions of all DVC and DAL devices are compatible on a DAL. Fiber option modules are required for fiber connections to new devices.

NFS2-3030 Single Panel Applications

with DVC and Digital Audio Loop (DAL).

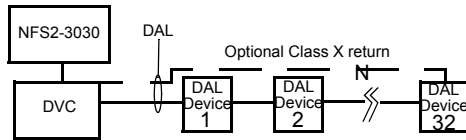

with DVC, DAL, and DVC-AO for retrofits.

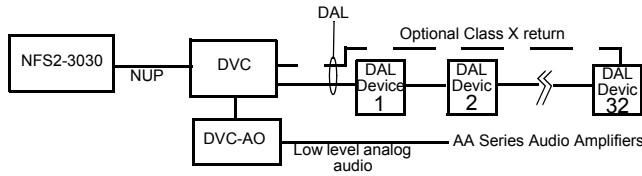

NFS2-640 Single Panel Applications

with DVC and DVC-AO for retrofits. DAL (digital audio loop) not compatible with this application.

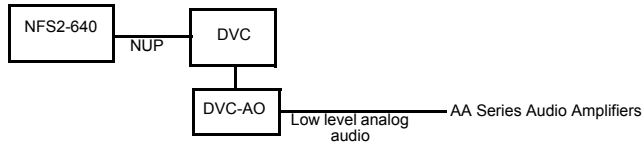

with DVC, NCA-2, DAL, and DVC-AO for retrofits.*

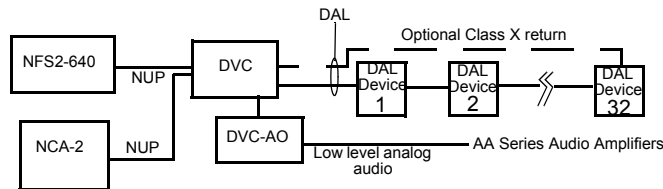

Networked System

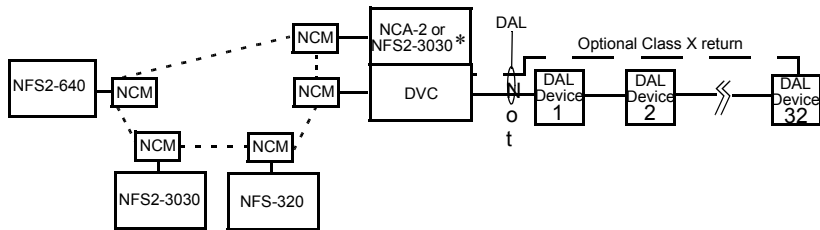

Networked System with Analog Equipment

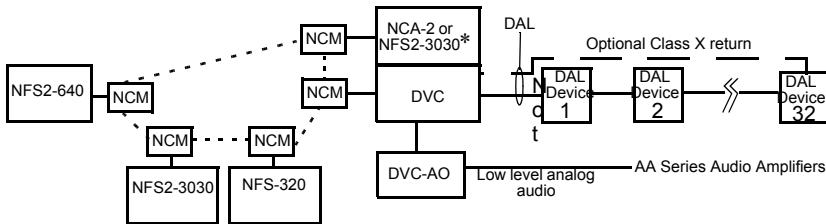

In this diagram, the term:

- "NCM" includes all network control modules, including high-speed versions. Note, however, that high-speed and standard NCMs may not be mixed on a network.
- "Noti•Fire•Net" includes standard and high-speed network versions.

* In this configuration, the DVC will only share General Zone activations with the NFS2-640. For example, logic zone activity in the DVC will not be usable in the NFS2-640.

** An NFS2-3030 must be in Network Display Mode to display DVC troubles. Refer to the NFS2-3030 programming manual for information on this mode.

An NCA, NFS-640, or NFS-3030 with compatible software may be part of a network.

Figure 1.2 Block Diagrams of DVC Applications

**NOTE:**

- Speaker placement must be given careful consideration when planning an audio system.
- Place speakers from different DALs (Digital Audio Loops) so they are not within the audible areas of other DALs.
- Carefully consider the audible range of speakers within a DAL; overlapping audio messages can be confusing.



NOTE: A maximum of 54 nodes may be used on a standard Noti•Fire•Net when digital audio messages will be broadcast over it. This limitation does not apply to a high-speed Noti•Fire•Net network, which accommodates up to 200 nodes with or without digital audio equipment.

1.2.1 Features

- Programmable from NUP or USB port using VeriFire Tools.
- Paging inputs include local and remote microphones, FFT handsets, Firefighter’s Telephone, two auxiliary inputs (1 V p-p and 12 V p-p) and paging from ONYXWorks.
- ONYXWorks workstations or additional DVCs can act as Noti•Fire•Net paging sources.
- Storage for up to 32 minutes of audio (.wav files) for voice messages or tones. At optional high quality audio setting, 4 minutes of audio files can be stored at a 44K samples per second resolution.
- 1000 custom messages can be created by the creation of message strings that reuse common audio segments.
- Customizable message prioritization.
- Equations use flexible CCBE programming for distribution of messages.
- 8 channel digital audio using the DAL (Digital Audio Loop) when using standard quality audio.
- 1 audio channel on the DAL when using high quality audio.
- 4 channel analog audio supported by optional DVC-AO analog output card.
- 1 audio channel on a standard or high-speed Noti•Fire•Net.
- Digital audio ports for direct connection with up to 2 digital audio loop devices, for a total of up to 32 devices on one DAL.
- Operates as a node on a standard or high-speed Noti•Fire•Net.
- DCC (Display and Control Center) capabilities when used with the DVC-KD.
- Multiple audio command centers supported on Noti•Fire•Net.
- Optional remote microphone.
- Functional with NFS2-3030 or NFS2- 640 as a standalone system (without Noti•Fire•Net).
- Firefighter’s Telephones
 - 5 FFT channels on the DAL
 - Local FFT handset (optional)
 - FFT riser on the DVC
 - Additional FFT risers on DAA and DAA2 series amplifiers, as well as DS-DB distribution boards.
 - FFT points can be answered or controlled via programmable DVC-KD points and/or ACS annunciator points.
- Broad paging functionality when used with DVC-KD via microphone, TELH-1 or FFT, RM-1, AUX A or AUX B inputs.
- Emergency paging buttons for All Call, Page Active Evac Areas, Page Active Alert Areas, and Page Inactive Areas.
- Auxiliary input for 12V p-p analog low-level audio sources.
- Auxiliary input for 1V p-p, to be used for background music input, and interface with a telephone paging source, or other compatible audio sources. Includes user audio level adjustment feature.
- Push-to-talk relay.
- Isolated alarm bus input, to be used for backup activation of alarm messages from a local FACP.
- Meets UL THD Distortion requirements. Refer to the DAA2/DAX and DS-DB manuals for individual amplifier distortion specifications.
- Meets ULC THD Distortion requirements. Refer to the DAA2/DAX and DS-DB manuals for individual amplifier distortion specifications.

1.2.2 Options

DVC-AO

The DVC-AO audio output board has four low-level analog outputs. It mounts on the DVC and is compatible with AA-30/E, AA-100/E, and AA-120/E amplifier products. Refer to Section “Analog Audio Outputs (DVC-AO)” on page 37.

DVC-KD

The DVC-KD keypad is for local annunciation and controls. Refer to “Using the DVC-KD Keypad on the DVC” on page 70 and “DVC-KD Keypad” on page 27 for more information on the DVC-KD.

DS-FM, DS-SFM, DS-RFM

These fiber option modules convert the DVC from a wire to a single or multi-mode fiber board. Refer to “Fiber Option Boards” on page 20 for more information.

1.2.3 Specifications

24VDC Power - TB1

24VDC input, 300 mA, alarm or standby, non-resettable, power-limited (Class 2) by the source, non-supervised.

- If a DVC-KD is attached, add: 60 mA
- If a DVC-AO is attached, add: 175 mA
- If an RM-1 is attached, add: 75 mA
- If one fiber module is attached, add: 60 mA
- If another fiber module is attached, add another: 60 mA
- For a possible total of: 730 mA alarm or standby

Recommended wiring: 14-18 AWG twisted-pair (max. 14 AWG.)

Digital Audio Ports A and B - TB2, TB3

Refer to the Wiring Guide, p/n 52916ADD, for acceptable wire types.

EIA-485 format.

Power-limited (Class 2).

Refer to “Fiber Option Boards” on page 20 for fiber specification and connection information. When a fiber option module is mounted on a DVC, it disables the corresponding wire terminals. TB3 (Digital Audio Port A) is disabled when a fiber option board is connected at J15. TB2 (DAP B) is disabled when a fiber option board is connected at J16.

Auxiliary Input A (AUX A) - TB 4

Signal strength from low-level analog audio input (such as background music or telephone paging): 1.6Vp-p max. for each circuit when both AUX A L and AUX A R are used. 3.2Vp-p max. for one when only one (AUX A L or AUX A R) is used.

Optional supervision through programming.

Recommended wiring: 18AWG, twisted-pair (max. 14 AWG).

Supervision programmable.

Auxiliary input source must be within 20 feet (6.01 m) of the DVC, and in the same room.

Auxiliary Input B (AUX B) - TB14

Signal strength from low-level analog audio input (AMG-style audio): 12Vp-p nominal, 15Vp-p max. Optional supervision through programming.

Recommended wiring: 14-18 AWG twisted-pair (max. 14 AWG.).

Supervision programmable.

Remote Microphone Interface - TB9

Recommended wiring: 14-18 AWG twisted-pair (max. 14 AWG.).

Nominal AC signal strength 2.5VRMS (3VRMS max).

Power-limited (Class 2).

Supervised.

Max distance between remote microphone and DVC: 1000 ft (300 m).

Push-to-talk Interface - TB10

Dry contact.

Common, non-supervised.

Recommended wiring: 14-18 AWG twisted-pair (max. 14 AWG).

Alarm Bus - TB12

Power-limited (Class 2) by source.

Non-supervised.

Recommended wiring: 14-18 AWG twisted-pair (max. 14 AWG.).

Requires 16 VDC minimum @ 20mA across the terminals to activate. Nominal 24VDC.

FFT Riser - TB13

Power-limited (Class 2) output.

Max: 15V, 75 mA AC.

Supervised.

Class A or Class B operation.

Class B 2-wire connections require a 3.9k ohm 1/2 watt end-of-line resistor (P/N R-3.9K).

Max. wiring resistance (including individual telephone zone to last handset) permitted is 50 ohms, 10,000 ft. (3048 m) max. wiring distance at 14 AWG twisted-pair (shielded recommended) to last handset.

Optional DVC-AO Analog Audio Output Circuits - TB5, TB6, TB7 and TB8

- Power-limited (Class 2) outputs.
- Signal strength: 12Vp-p (max 15Vp-p 150 mA).
- Supervision programmable.
- Recommended wiring: 18 AWG max, twisted-pair (max. 14 AWG).
- Max impedance: 66 ohms.
- Distance based on impedance.
- Class A or Class B operation.

1.3 DVC Board Layout

1.3.1 Connections

Board connections for the DVC are illustrated and identified in Figure 1.3.

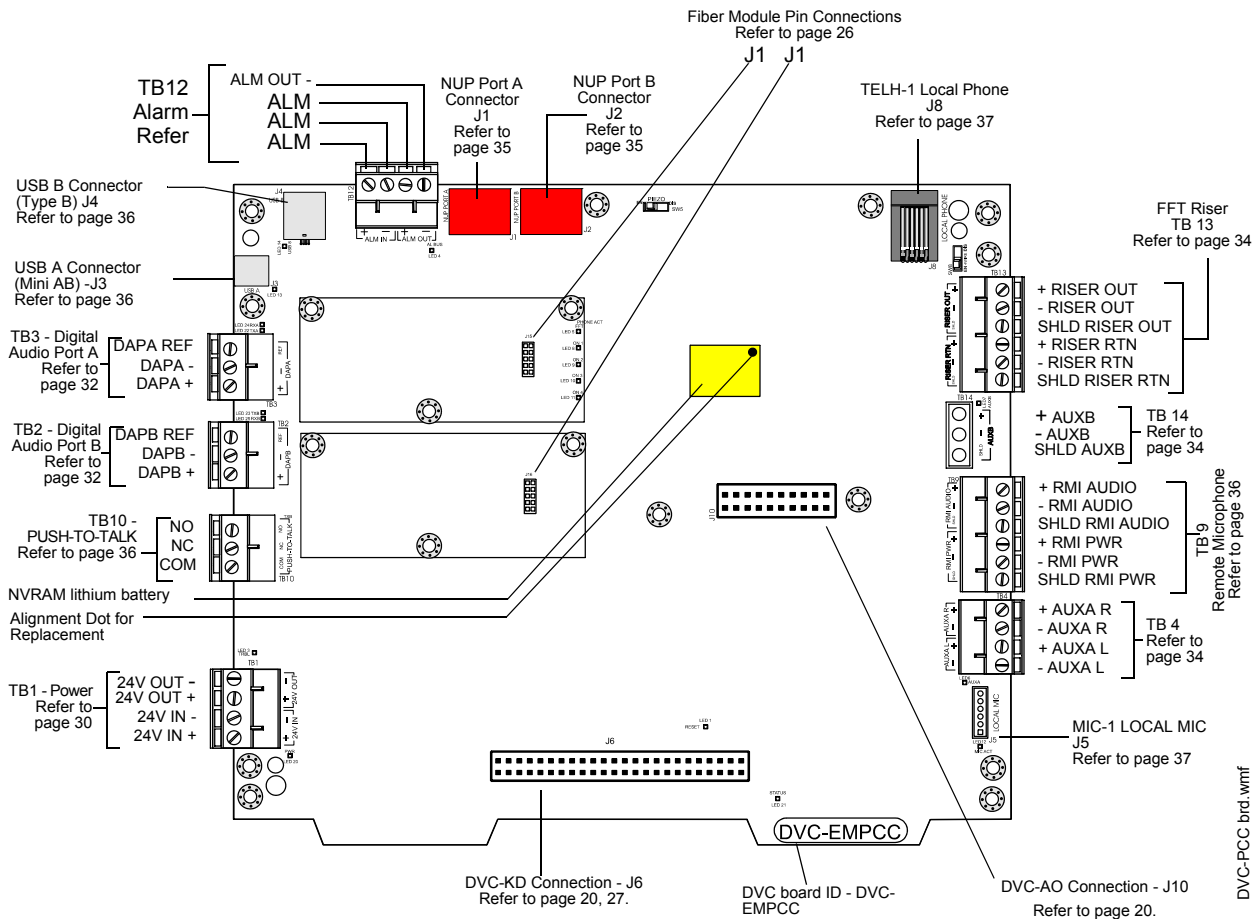

Figure 1.3 Connections

1.3.2 Switches and Indicators

Switches and LED indicator locations on the DVC are illustrated in Figure 1.4.

Switches and Indicators:
Refer to Tables 1.1 and 1.2.

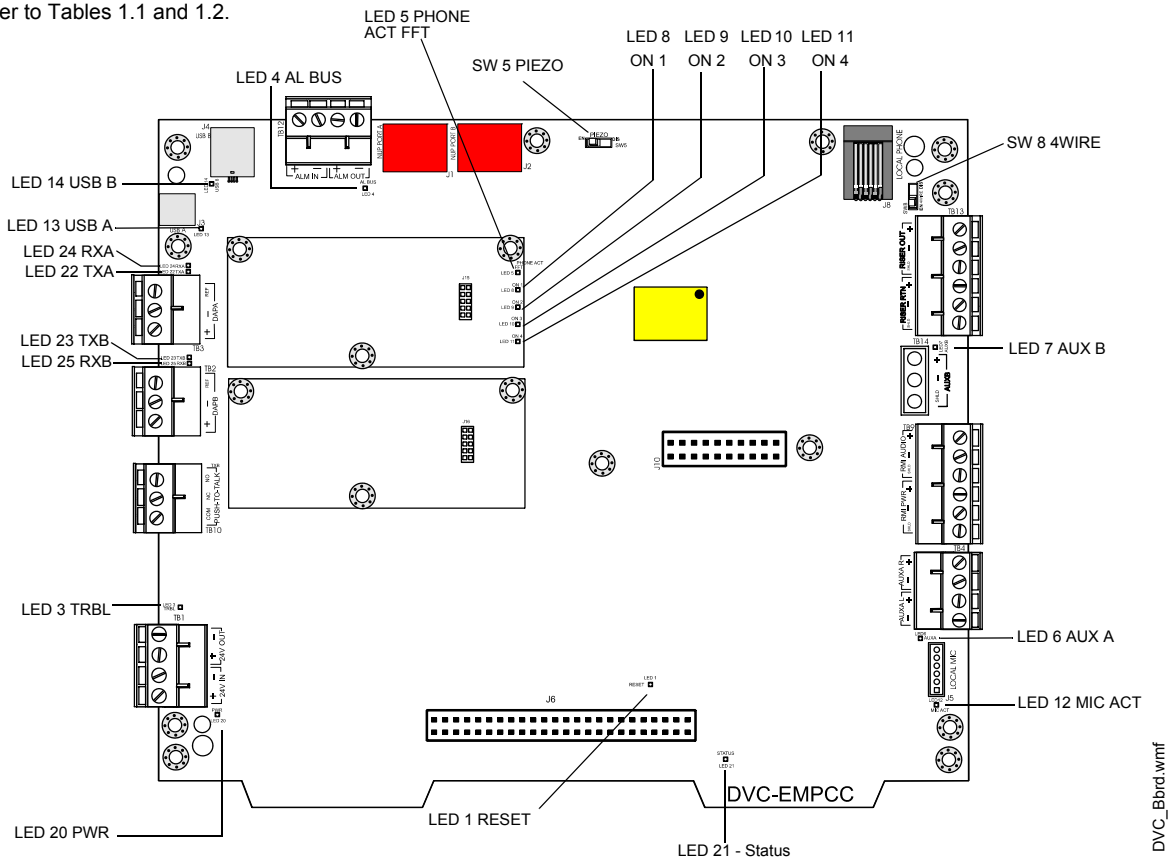

Figure 1.4 LED Indicator and Switch Locations

Switch Functions

The switches described in Table 1.1 are for configuration or for diagnostic purposes. All are located as indicated in Figure 1.4.

Name	Number	Description	Default
PIEZO	SW5	Enable/disable the piezo.	EN (enable/on)
4WIRE	SW8	Changes FFT Riser indication to 2- or 4-wire, depending on whether the riser is wired Class B or Class A.	2-wire

Table 1.1 DVC Switches

Indicators

The diagnostic LEDs indicate various conditions and troubles. All are located as indicated in Figure 1.4.

LED Name	Color	Description	LED #
RESET	Yellow	Factory use only	1
TRBL	Yellow	Illuminates when a trouble occurs. Blinks for an unacknowledged trouble, illuminates steadily for an acknowledged trouble.	3
AL BUS	Red	Illuminates steadily while the DVC's alarm bus input is active.	4
PHONE ACT FFT	Green	Illuminates steadily while at least one firefighter's telephone is active on a DAL device riser.	5
AUX A	Green	Illuminates steadily while audio is detected on AUX IN A.	6
AUX B	Green	Illuminates steadily while audio is detected on AUX IN B.	7
ON 1	Green	Illuminates steadily while analog signal is on audio output 1.	8
ON 2	Green	Illuminates steadily while analog signal is on audio output 2.	9
ON 3	Green	Illuminates steadily while analog signal is on audio output 3.	10
ON 4	Green	Illuminates steadily while analog signal is on audio output 4.	11
MIC ACT	Green	Illuminates steadily while push-to-talk is activated on the MIC-1 microphone.	12
USBA	Green	Illuminates steadily when a connection is made.	13
USBB	Green	Illuminates steadily when a connection is made.	14
PWR	Green	Illuminates steadily while local 24V from power supply is present.	20
STATUS	Green	Blinks slowly (once a second) under normal operation, Blinks fast (4 times a second) when the DVC is in bootload or diagnostic mode. Does not blink when the board is not operational or starting up. Call the factory if this LED is off for a prolonged period of time.	21
TXA	Green	Illuminated while data is transmitted on Digital Audio Port (DAP) A. Illumination will flicker on wire versions, turning on when activity is detected and off when it is not. LED does not illuminate for fiber media.	22
TXB	Green	Illuminated while data is transmitted on Digital Audio Port (DAP) B. Illumination will flicker on wire versions, turning on when activity is detected and off when it is not. LED does not illuminate for fiber media.	23
RXA	Green	Illuminated while data is received on Digital Audio Port (DAP) A. Illumination will flicker on wire versions, turning on when activity is detected and off when it is not. LED does not illuminate for fiber media.	24
RXB	Green	Illuminated while data is received on Digital Audio Port (DAP) B. Illumination will flicker on wire versions, turning on when activity is detected and off when it is not. LED does not illuminate for fiber media.	25

Table 1.2 DVC LED Indicators

1.4 Options

1.4.1 DVC-AO Analog Output Board Layout

Refer to “Analog Audio Outputs (DVC-AO)” on page 37 for information on wiring these connections. See Figure 2.4, “Mounting a DVC-AO” on page 26 for information on mounting it onto a DVC.

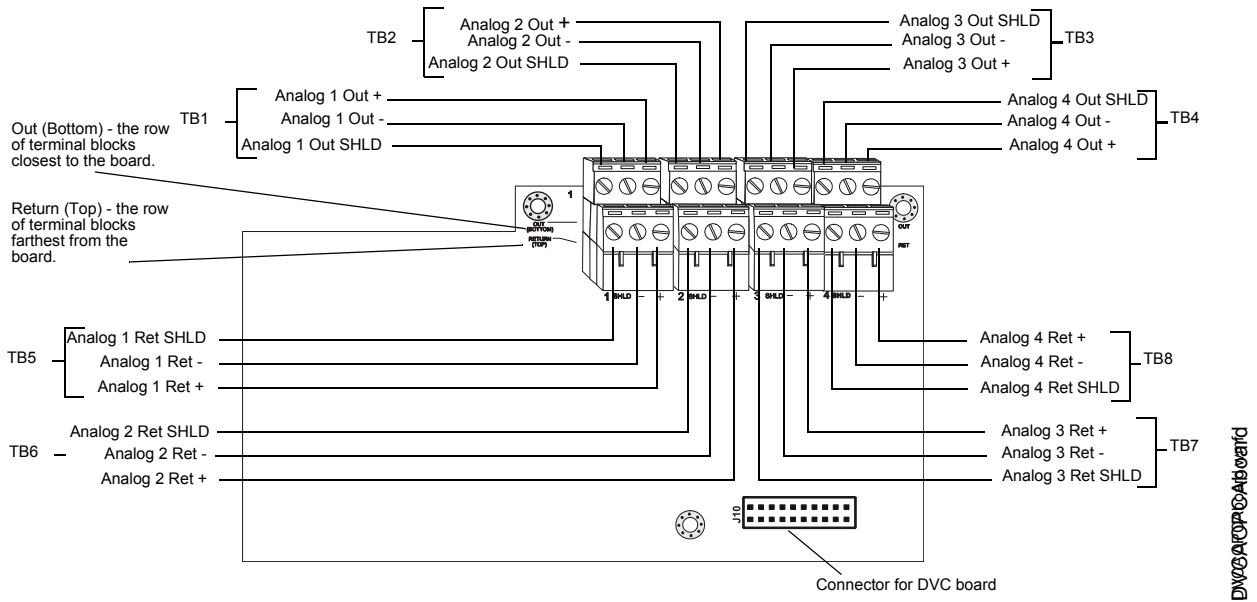

Figure 1.5 DVC-AO Board Layout

1.4.2 DVC-KD Keypad

The DVC-KD is used for paging and message routing functions, with status LEDs for certain functions and 24 user-programmable annunciator-type buttons. Refer to Section 2.5.3 on page 27 for information on mounting the keypad and slide-in labels, and “Using the DVC-KD Keypad on the DVC” on page 70 for information on the keypad’s operation.

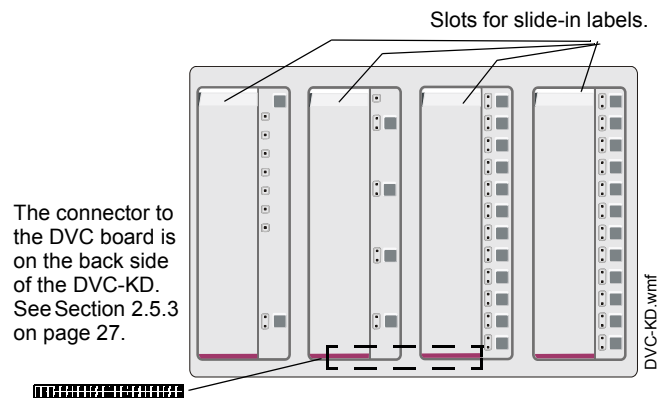

Figure 1.6 DVC-KD Keypad

1.4.3 Fiber Option Boards

The DVC supports wire media as shipped. Use of fiber optic media requires the use of fiber option modules. Each DVC can be used with either one or two modules. This flexibility allows for the creation of digital audio networks with mixed wire, multi-mode fiber, and single-mode fiber segments on the same loop. Fiber option modules consist of the following models.

Model	Fiber Type	For direct fiber connection between the DVC and...
DS-FM	multi-mode	Any DAA2 or DAX model, DS-DB, or DVC-RPU. LC Style fiber connectors at both ends.
DS-SFM	single-mode	<ul style="list-style-type: none"> Any DAA2 or DAX model, DS-DB, or DVC-RPU. LC Style fiber connectors at both ends. A single-mode fiber DAA Series amplifier. LC Style fiber connector at DVC end, ST® style fiber connector at DAA end.
DS-RFM	multi-mode	A multi-mode fiber DAA Series amplifier. LC Style fiber connector at DVC end, ST® style fiber connector at DAA end.

Table 1.3 Fiber Option Boards



NOTE: Whenever a fiber option module is used on a DAL device port, the next DAL device that is linked to that port must have the same model fiber option module or equivalent style DAA.

One or two fiber option modules may be connected to a DVC to convert it from a board with two wire DAP ports to:

- a board with one wire and one fiber port,
- a board with two single-mode fiber ports,
- a board with two multi-mode fiber ports, or
- a board with one single-mode and one multi-mode fiber port.

When a fiber option module is mounted on a DVC, it disables the corresponding wire terminals. TB3 (Digital Audio Port A) is disabled when a fiber option board is connected at J15. TB2 (DAP B) is disabled when a fiber option board is connected at J16.

Specifications

Single- and Multi-mode Fiber-Optic Digital Audio Ports

LC Style connection.

Supervised.

Fiber optic cable, multi-mode: 50/125 or 62.5/125 micrometers.

Fiber optic cable, single-mode: 9/125 micrometers.

Attenuation of cabling between two nodes (fiber-optic circuits are point-to-point) must not exceed the maximum attenuation, specified below.

To determine attenuation:

1. Find the rated dB loss per foot within the cable manufacturer's specifications. Determine the total attenuation between the two nodes due to the cable.
Loss = (loss/ft.) x (length in feet)
2. Establish the dB loss for each connector and splice. Sum all the losses.
3. Total the attenuation factors obtained in steps 1 and 2. This will provide an approximate attenuation total. The actual attenuation should be measured end-to-end with fiber-optic industry standard equipment.

- **DS-FM and DS-SFM (except when directly connected to a fiber DAA)**

The maximum attenuation:

- 6.5dB for multi-mode with 50/125 micrometer cable @ 1310 nm.
- 10dB for multi-mode with 62.5/125 micrometer cable @ 1310 nm.
- 30dB for single-mode with 9/125 micrometer cable @ 1310 nm.

- **DS-SFM/Single-mode fiber DAA Connection**

The maximum attenuation:

- 17dB for single-mode with 9/125 micrometer cable at 1310 nm going *from* the DS-SFM *to* the fiber DAA.
- 4dB for single-mode with 9/125 micrometer cable going *from* fiber DAA *to* the DS-SFM.

The minimum attenuation:

- 12dB minimum* going *from* the DS-SFM *to* the fiber DAA.
*If the length of the fiber run results in an attenuation of less than 12dB, a suitable attenuator must be used.

- **DS-RFM/Multi-mode fiber DAA Connection**

Attenuation going *from* the fiber DAA *to* the DS-RFM:

- 2dB maximum for multi-mode with 50/125 micrometer cable @ 850 nm for the DS-RFM.
- 4dB maximum for multi-mode with 62.5/125 micrometer cable @ 850 nm for the DS-RFM.

Attenuation going *from* the DS-RFM *to* the fiber DAA:

- 12dB minimum*, 16dB maximum for both cable types.
*If the length of the fiber run results in an attenuation of less than 12dB, a suitable attenuator must be used.

The DS-FM, DS-SFM and DS-RFM look the same. The silkscreened board name that applies will be visible: those that do not apply will be crossed off.

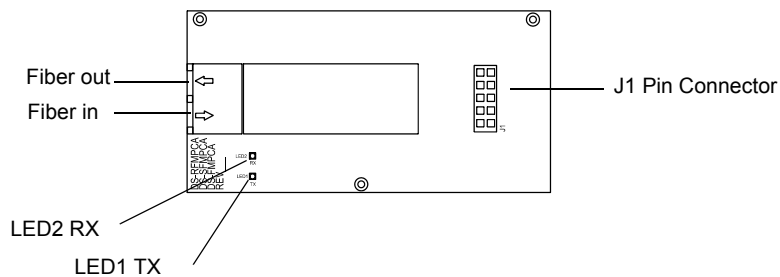

Figure 1.7 Fiber Option Module.

LED #	NAME	COLOR	DESCRIPTION
1	TX	Green	Illuminates while data is transmitted on the digital audio port. Light will flicker, turning on when activity is detected and off when it is not.
2	RX	Green	Illuminates while data is received on the digital audio port. Light will flicker, turning on when activity is detected and off when it is not.

Table 1.4 Fiber Option Module Board LEDs

Section 2: DVC Installation

2.1 Overview

2.1.1 Chassis

DVC boards will mount in a size B, C or D CAB-4 series cabinet, in either one of the following chassis assemblies:

- CA-2 - This chassis assembly occupies two rows of a CAB-4 series enclosure. The left side accommodates a DVC board mounted on a half-chassis and one NFS2-3030 or NCA-2 mounted on a half-chassis. The right side houses a microphone and handset well. (Refer to Figure 2.1.)
A MIC-1 microphone (not pictured) is included with the chassis assembly. A TELH-1 telephone handset may be ordered separately.

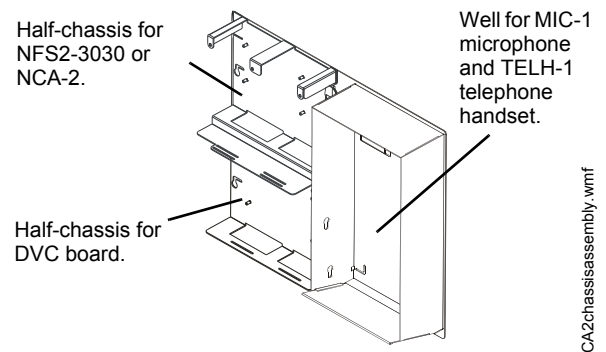

Figure 2.1 CA-2 Chassis Assembly

- CA-1 - This chassis occupies one row of a CAB-4 series enclosure. The left side accommodates one DVC board, and the right side houses an optional CMIC-1, which consists of a MIC-1 microphone and well.
A CFFT-1 chassis for Firefighter's Telephone may be used with the CA-1 to add an FFT. Refer to Section 2.8 on page 29 for information on this installation.

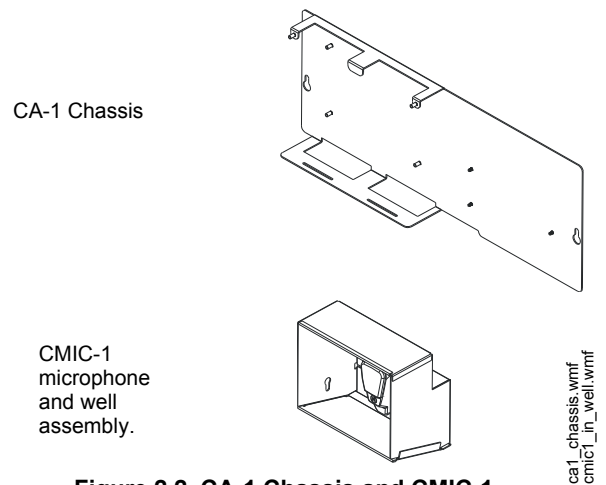

Figure 2.2 CA-1 Chassis and CMIC-1

2.1.2 Doors and Dress Panels

Doors for CA-2 Installations

Doors with clear window space revealing the audio command center components may be ordered for the CAB-B4, CAB-C4 and CAB-D4 enclosures. Add the "R" for red doors/backboxes.

- ADDR-B4/R - This door reveals a CA-2 with NFS2-3030/NCA-2, DVC board with keypad, and microphone and handset in the two rows of the "B" size cabinet (P/Ns SBB-B4/R).
- ADDR-C4/R - This door reveals the top two rows the same as the ADDR-B4, but also reveals the third row of the "C" size cabinet (P/Ns SBB-C4/R).
- ADDR-D4/R - This door reveals the top three rows the same as the ADDR-C4, but also reveals the fourth row of the "D" size cabinet (P/Ns SBB-D4/R).

Doors for CA-1 Installations

For CA-1 installations, use standard CAB-4 Series doors based on the cabinet size used. (P/Ns DR-A4/-A4R/-A4B/-A4BR for "A" size cabinets, DR-B4/-B4R/-B4B/-B4BR for the "B" size, DR-C4/-C4R/-C4B/-C4BR for the "C" size, DR-D4/-D4R/-D4B/-D4BR for the "D" size.

Dress Panels for CA-2 Installations

The DPA-2 dress panel has an opening revealing the audio command center components in a CA-2 chassis. It covers two rows in any CAB-4 series enclosure.

Requires a VP-2B ventilation panel if the CA-2 is in the top two rows.

Dress Panels for CA-1 Installations

The DPA-1 dress panel has an opening revealing a DVC keypad and CMIC-1.

The DPA-1A4 is used for applications without a CMIC-1, to cover the two empty right-hand spaces with blank plates, or to fill the right-hand spaces with annunciator or option cards.

The DP-1B blank dress panel may be used to completely cover an installation without a DVC-KD and CMIC-1.

The DP-CFFT covers the CFFT-1 chassis, which is used to mount a Firefighter's Telephone and one optional ACS annunciator.

2.2 Prepare for Installation

Carefully unpack the equipment and inspect for shipping damage.

Before installation:

- Review the installation precautions at the front of this manual.
- Installers should be familiar with the standards and codes specified in “**Standards and Other Documents**” on page 9.
- Ensure all wiring will comply with national and local codes.
- Review installation instructions in “Installation Checklist” on page 25.



WARNING: INSTALL SYSTEM COMPONENTS IN SEQUENCE

INSTALL THE SYSTEM COMPONENTS IN THE SEQUENCE LISTED BELOW. FAILURE TO DO SO CAN DAMAGE THE COMPONENTS.



WARNING: STATIC DISCHARGE CAN DAMAGE EQUIPMENT

WEAR A STATIC DISCHARGE STRAP ON WRIST TO PREVENT EQUIPMENT DAMAGE.

2.3 Installation Checklist

Task	Refer to:
Mount the cabinet backbox to the wall.	"Cabinet" on page 25.
Mount the CA-1 or complete CA-2 chassis assembly into the backbox either at this point or after the components have been installed on the chassis.	CA-1 or CA-2 Chassis Product Installation Document.
Mount any option boards to the DVC. <ol style="list-style-type: none"> 1. Fiber option module(s) 2. DVC-AO. 3. DVC-KD. 	<ol style="list-style-type: none"> 1. Section 2.5.1 on page 26. 2. Section 2.5.2 on page 26. 3. Section 2.5.3 on page 27.
<u>Load the CA-1 Chassis</u> <ol style="list-style-type: none"> 1. Optional: Mount an NCM or HS-NCM to the chassis. 2. Mount the DVC in its chassis position. 3. Optional: Mount the CMIC-1 microphone and chassis well or CFFT-1. 	<ol style="list-style-type: none"> 1. Section 2.6 on page 28. 2. Section 2.7 on page 28. 3. CA-1, CMIC-1, and CFFT-1 Product Installation Document.
<u>Load the CA-2 Chassis</u> <ol style="list-style-type: none"> 1. Optional: Mount an NCM or HS-NCM onto the DVC half-chassis. 2. Mount the DVC onto its half-chassis. 3. Optional: Mount an LCM-320 or stacked LCM-320/LEM-320 onto the NFS2-3030 half-chassis. 4. Mount the NFS2-3030 or NCA-2 onto its half-chassis. 5. Mount the MIC-1 and optional TELH-1 handset into the chassis well. 	<ol style="list-style-type: none"> 1. Section 2.6 on page 28. 2. Section 2.7 on page 28. 3. NFS2-3030 installation manual. 4. NFS2-3030 installation manual or NCA-2 manual. 5. CA-2 installation document.
Slide chassis component(s) aside for wiring.	CA-1 - Section 2.9.1 on page 29 CA-2 - Section 2.9.2 on page 30
Wire and program the panel.	NFS2-640, NFS2-3030 or NCA-2 manuals.
Wire and configure the DVC.	Sections 2.10, "Wiring" and 3.1, "Setting the Configuration Switches" in this manual.
Program the DVC.	Section 3.2, "Programming", on page 40, and help files.
Install dress panels, doors and covers.	Cabinet and Chassis Installation documents.
Test the system.	

Table 2.1 DVC Installation Checklist

2.4 Cabinet

Locate the cabinet backbox on a surface that is in a clean, dry, vibration-free area. The top should be located so that all operational buttons, switches, displays, etc. are easily accessible and/or viewable to the operator - usually no more than 66 inches (1.7 m) above the floor. Allow sufficient clearance around the cabinet for the door to swing freely, and for easy installation and maintenance of equipment.

Use the four holes in the back surface of the backbox to provide secure mounting. Follow the instructions below.

1. Mark and pre-drill two holes for the keyhole mounting bolts. Install bolts.
2. Select and punch open the appropriate cabinet knock-outs.
3. Using the keyholes, mount the backbox on the two bolts.
4. Mark the location for the two lower holes, remove the backbox and drill the mounting holes.
5. Mount the backbox over the top two screws, then install the remaining fasteners. Tighten all fasteners securely.
6. Feed wires through appropriate knockouts.
7. Install the Digital Voice Command according to this section before installing the door per the CAB-4 Series Cabinet Installation Document.

2.5 Mount DVC Option Boards

Option boards should be mounted to the DVC at this point. If both the DVC-AO and DVC-KD are used, the DVC-AO must be mounted first, as it fits behind the DVC-KD.

2.5.1 Installing Fiber Option Modules

Install fiber option modules as indicated in Figure 2.3 below.

1. Screw in option module standoffs at holes indicated. Each module requires three standoffs, included.
2. Align option module over the standoffs and plug into DVC at pin connector J15 or J16.
3. Screw module to standoffs with three screws (included with option module).

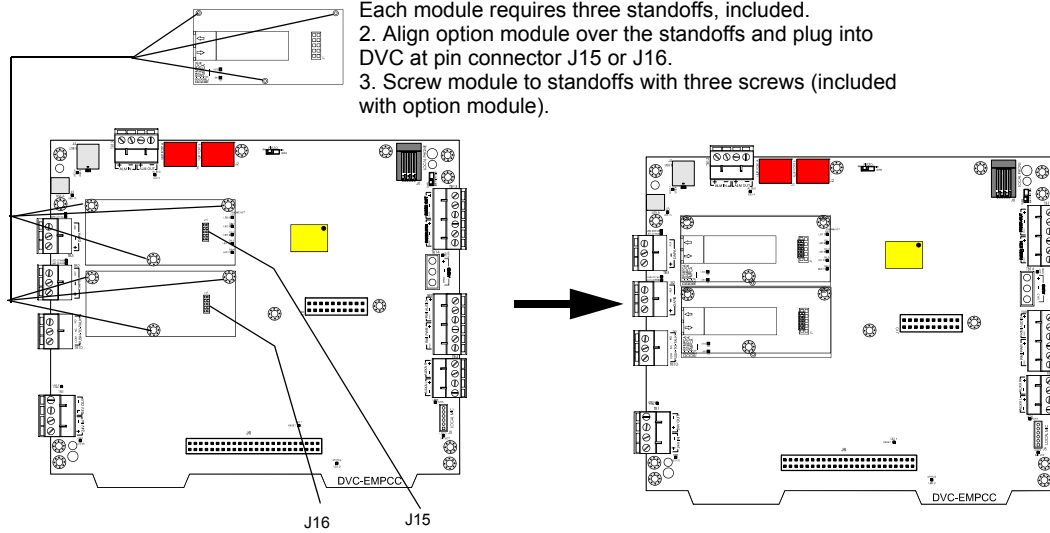

Plugging a fiber option module into J15 disables TB3 (DAP A).
 Plugging a fiber option module into J16 disables TB2 (DAP B).

Figure 2.3 DVC Fiber Option Module Installation

2.5.2 DVC-AO Analog Output Board

Mount the DVC-AO according the instructions in Figure 2.4.

1. Position three 1-1/4" female aluminum standoffs (included) in holes in the DVC board where indicated.

2. Fasten them at the back of the board with three 4-40 screws (included).

3. Carefully attach the DVC-AO pin connector (included) to the DVC board at J10.

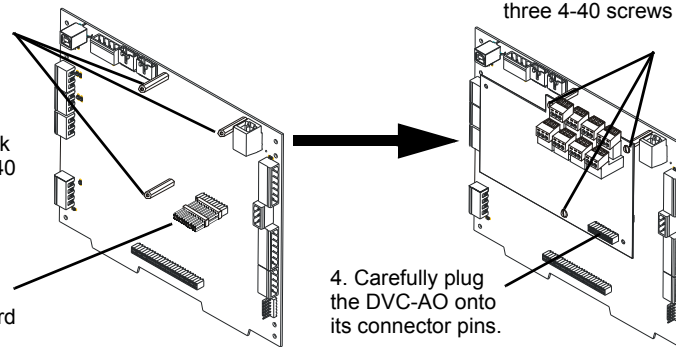

4. Carefully plug the DVC-AO onto its connector pins.

5. Attach to the DVC with three 4-40 screws (included).

DVCwAOstandoffs.wmf
 DVCandAO.wmf

Figure 2.4 Mounting a DVC-AO

2.5.3 DVC-KD Keypad

Mount the DVC-KD according to the instructions in Figure 2.5.

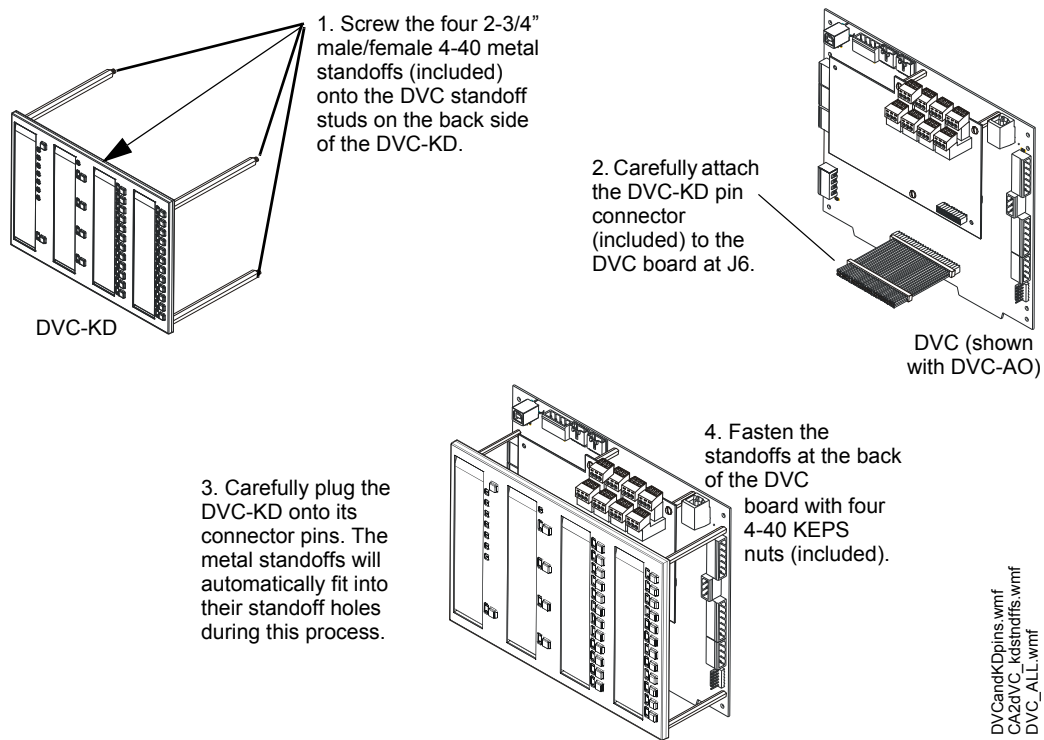

Figure 2.5 Mounting a DVC-KD

Insert the slide-in labels that come with the DVC-KD keypad. Install the pre-printed labels in the two left slots. There are two labels with ALL CALL; one with and one without text descriptions of the bottom three buttons (See Figure 2.6). For single-channel systems where the Digital Voice Command and digital audio amplifiers will always play the same audio message, the three buttons have no function and the alternate label should be inserted.

The two right slots provide for 24 annunciator-type functions that can be programmed in VeriFire Tools. Once they are programmed, label accordingly. For a custom professional appearance, generate the labels with Notifier's LabelEase.

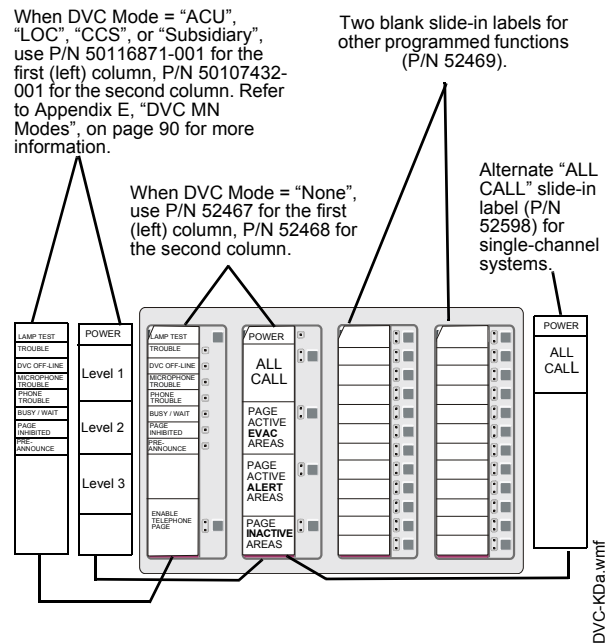

Figure 2.6 DVC-KD with Slide-in Labels

2.6 Mount a Network Communications Module in a CA-1 or CA-2 Chassis

A standard (NCM-W/F) or high-speed (HS-NCM-W/SF/MF/SWF/WMF/MFSF) network communications module can be mounted behind a DVC board in either the CA-1 or CA-2 chassis. Figure 2.7 illustrates how to install it in a CA-1. Mounting is the same behind a DVC board in the lower half-chassis of a CA-2.

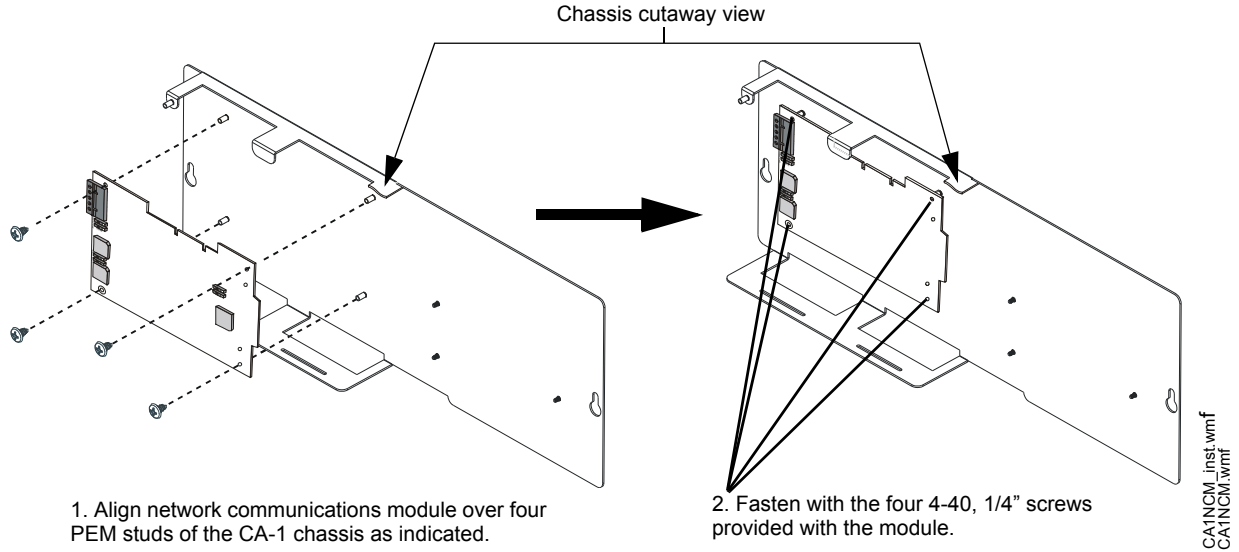

Figure 2.7 Installing a Network Communications Module (CA-1 Example)

CA-2 installations may require that a second network communications module be mounted in the cabinet; one for the DVC and another for the FACP or network annunciator. This will require another cabinet row. The network communications module may be mounted on a DAA chassis if one is installed in the cabinet (see the DAA2/DAX manual for details), or it may be mounted in any chassis that will accommodate it in the cabinet.

2.7 Mount a DVC Board in a CA-1 or CA-2 Chassis

Figure 2.8 illustrates a CA-1 installation. Mounting is the same in the lower half-chassis of a CA-2.

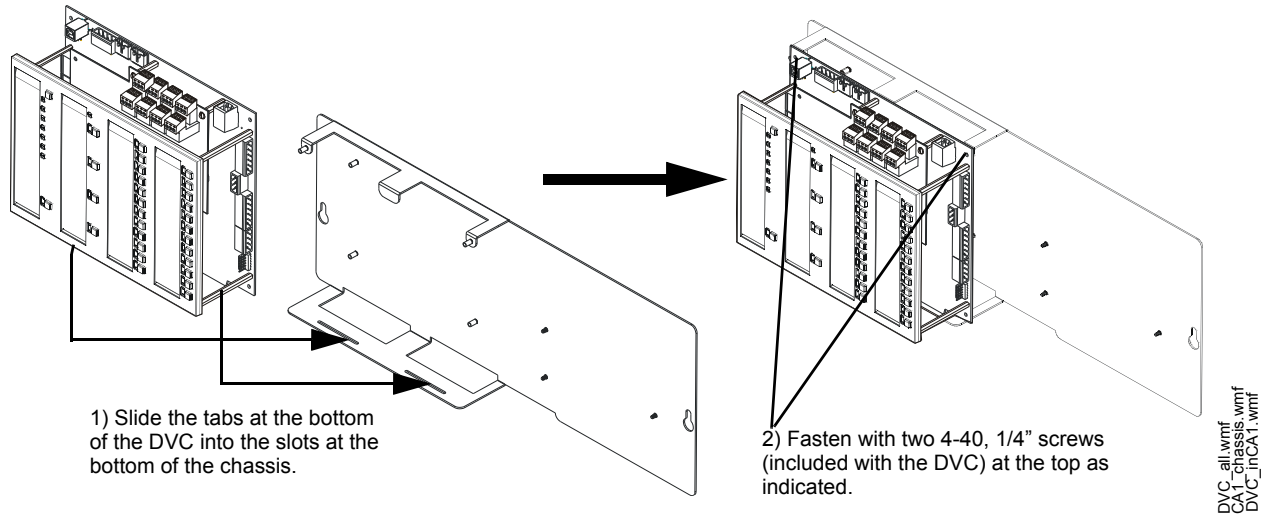

Figure 2.8 Chassis Mounting (CA-1 Example)

2.8 Using a CFFT-1 with the CA-1 Chassis

The CFFT-1 Chassis for Firefighter’s Telephone may be used to add a Firefighter’s Telephone (and one optional ACS annunciator) to a DVC mounted in a CA-1 chassis. The CFFT-1 must be mounted in the row directly under the CA-1 chassis (see Figure 2.9 at right).

A DP-CFFT dress panel can be used to cover the row. Refer to the CFFT-1 product installation document for installation details.

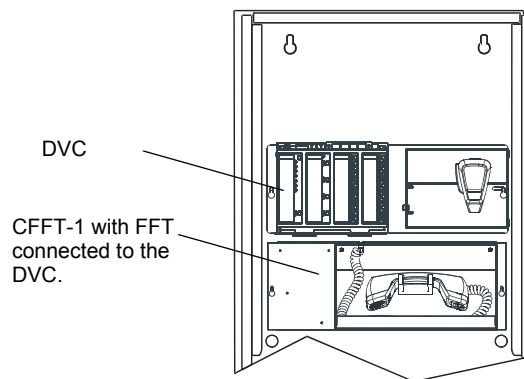

Figure 2.9 CFFT-1 Under a CA-1

2.9 Move the Chassis for Wiring Access

2.9.1 CA-1

The CMIC-1 chassis can be moved aside on the CA-1 to provide more space around the field-wiring connections. Loosen hex nuts and move the chassis to the side as indicated in Figure 2.10.

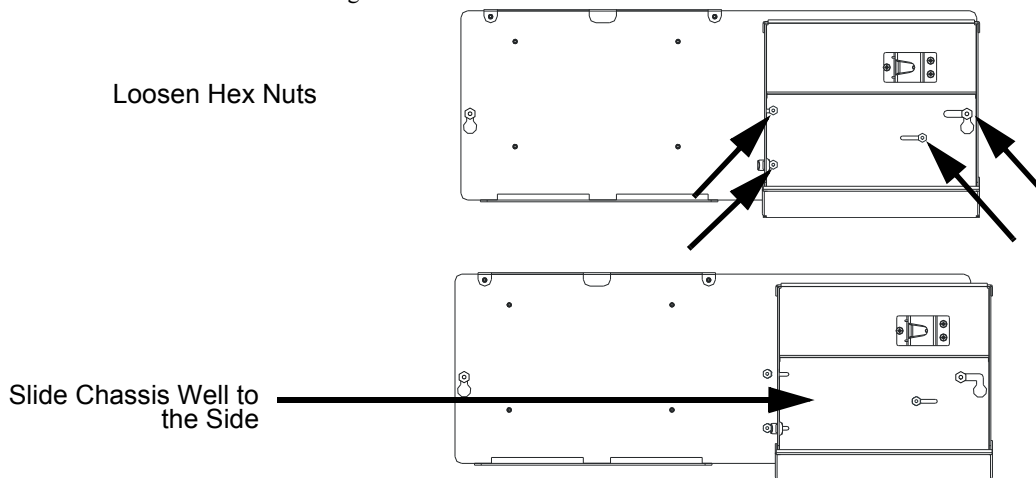

Figure 2.10 Moving the CMIC-1 Chassis Aside for Wiring Access



CAUTION: RE-SECURE THE HEX NUTS TO PREVENT EQUIPMENT DAMAGE.

AFTER RETURNING THE CMIC-1 CHASSIS TO ITS STANDARD POSITION, TIGHTEN ALL HEX NUTS. IF THE NUTS ARE NOT RE-SECURED, THEY COULD CONTINUE TO LOOSEN EACH TIME THE WELL IS MOVED AND MAY EVENTUALLY FALL OFF.

2.9.2 CA-2

To provide more space around the field-wiring connections, loosen hex nuts and move chassis components to the side. Each half-chassis slides to the left; the double-well slides to the right.

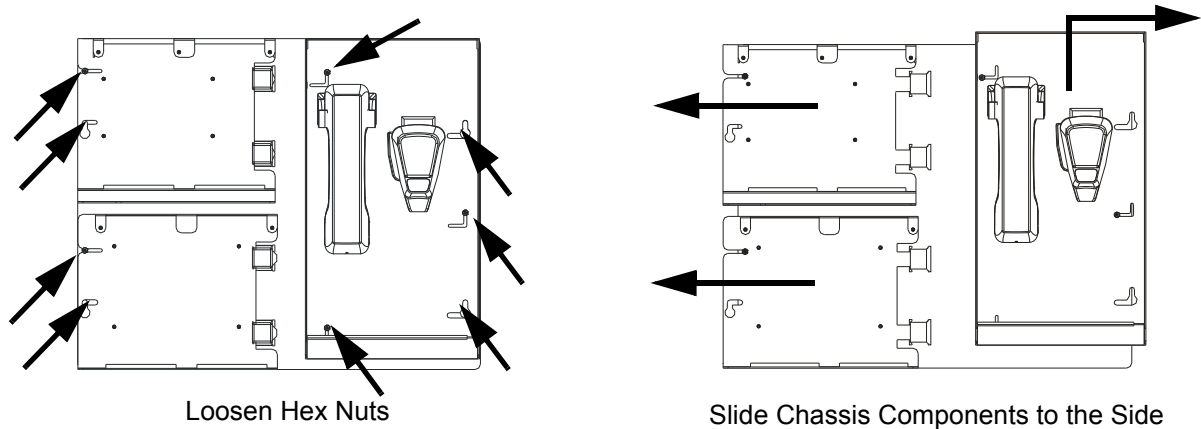

Figure 2.11 Moving Aside the CA-2 Chassis Components for Wiring Access



CAUTION: RE-SECURE THE HEX NUTS TO PREVENT EQUIPMENT DAMAGE.

AFTER RETURNING THE DOUBLE-WELL AND HALF-CHASSIS TO THEIR STANDARD POSITION, TIGHTEN ALL HEX NUTS. IF THE NUTS ARE NOT RE-SECURED, THEY COULD CONTINUE TO LOOSEN EACH TIME THE DOUBLE-WELL IS MOVED AND MAY EVENTUALLY FALL OFF.

2.10 Wiring

2.10.1 DVC Board to 24V Power

TB1 IN

- Connect to a non-resettable +24V output of an ONYX[®] panel or a local power supply capable of supplying the DVC's power requirements. (For requirements, see "24VDC Power - TB1" on page 16.) Refer to the appropriate panel or power supply manual for connections.
- Power-limited (Class 2) by the source.
- The power supply must be monitored from an ONYX[®] panel or an NCA-2.

TB1 OUT - Typically used to power annunciators.

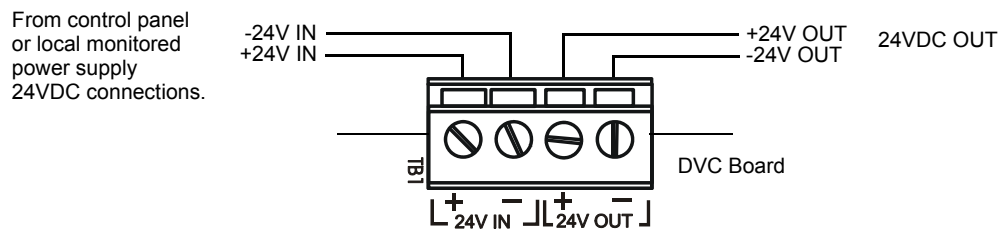

Figure 2.12 TB1 - 24 Volt Power Connections

DVC24V/tb1.wmf

2.10.2 Alarm Bus

The TB12 general alarm connections provide the option of receiving general alarm messages from an FACP via an SLC device, or via a Notification Appliance Circuit of an FACP or power supply.

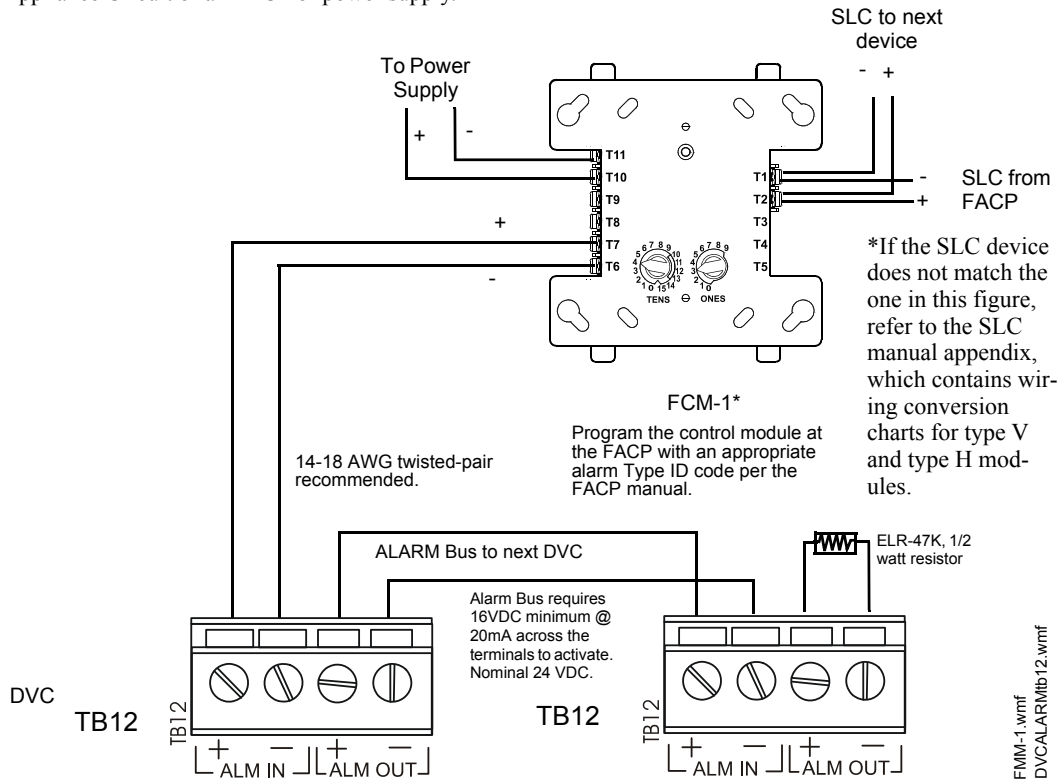

Figure 2.13 Alarm Bus Connections to FCM-1

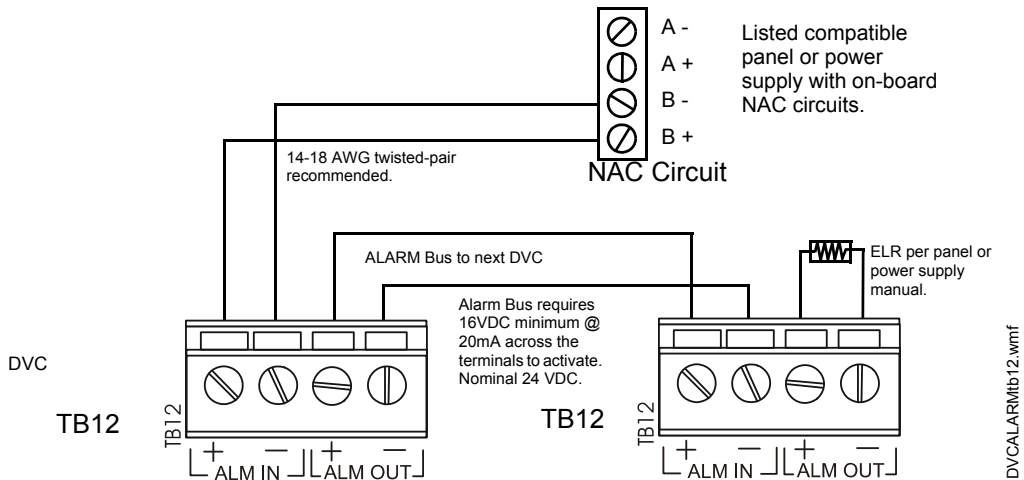

Figure 2.14 Alarm Bus Connections to NAC

Refer to the SLC manual and specific panel or power supply manual for more information.

2.10.3 Digital Audio Ports A and B

Connections between these ports provide a Digital Audio Loop (DAL) for programming, for alarm, control, trouble, automatic audio messages, and for address and Firefighter’s Telephone data, as well as live voice paging communications.

Wire Terminals

Digital Audio Ports A and B (DAP A and DAP B) support a direct connection with digital audio loop devices that have wire DAP terminals.

See “Digital Audio Ports A and B - TB2, TB3” on page 16 as well as the Wiring Guide, p/n 52916ADD, for cable types and associated distances between ports.

NOTE: Do not splice a cable. Splicing will degrade the signal, and the recommended distance will no longer apply.

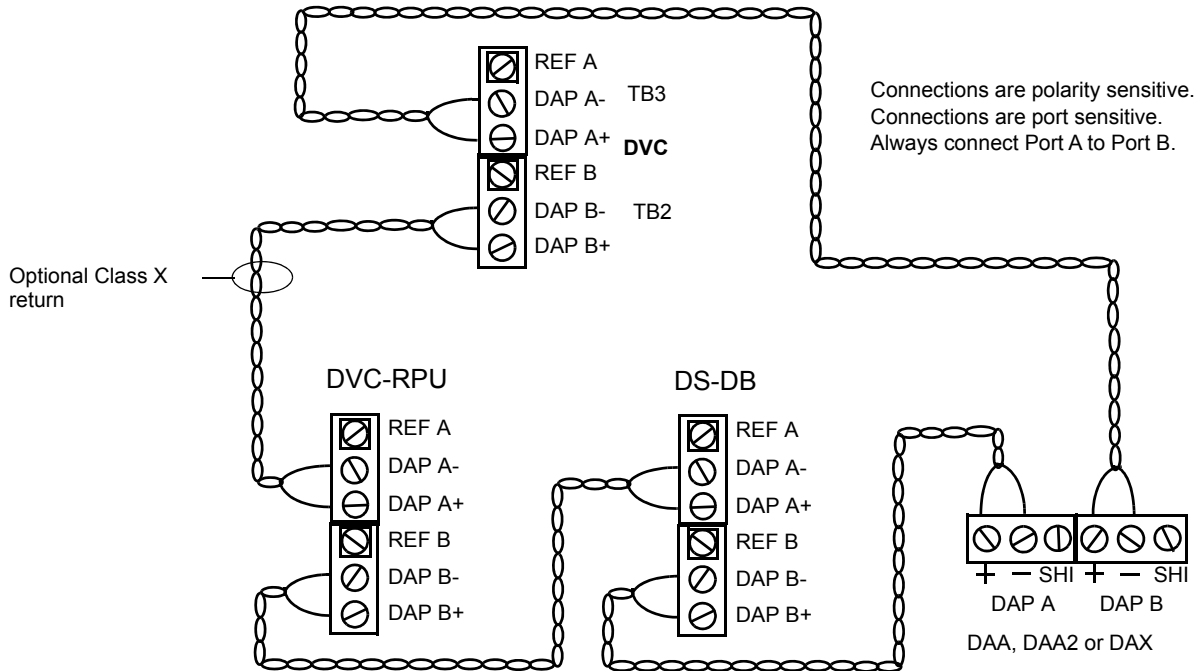

Figure 2.15 Wire DAL Connections



NOTE: Digital Audio Ports A and B must be wired in Class B or Class X configuration. Do not wire them in bus configuration.



NOTE: Class B configuration must be installed in accordance with the requirements for survivability from attack by fire in the National Fire Alarm Code, NFPA 72.

Refer to Appendix A, “DAL Earth Fault Detection”, on page 74, for information on enabling earth fault detection on a Digital Audio Loop that contains a DAA.

Fiber Connections (Using Fiber Option Modules)

When a fiber option module is used to convert the DVC’s wire digital audio port to a fiber port, the DVC will provide a direct connection to any fiber DAL device.

Refer to “Fiber Option Boards” on page 20 for module usage. Note that the fiber option modules use LC style fiber connectors.

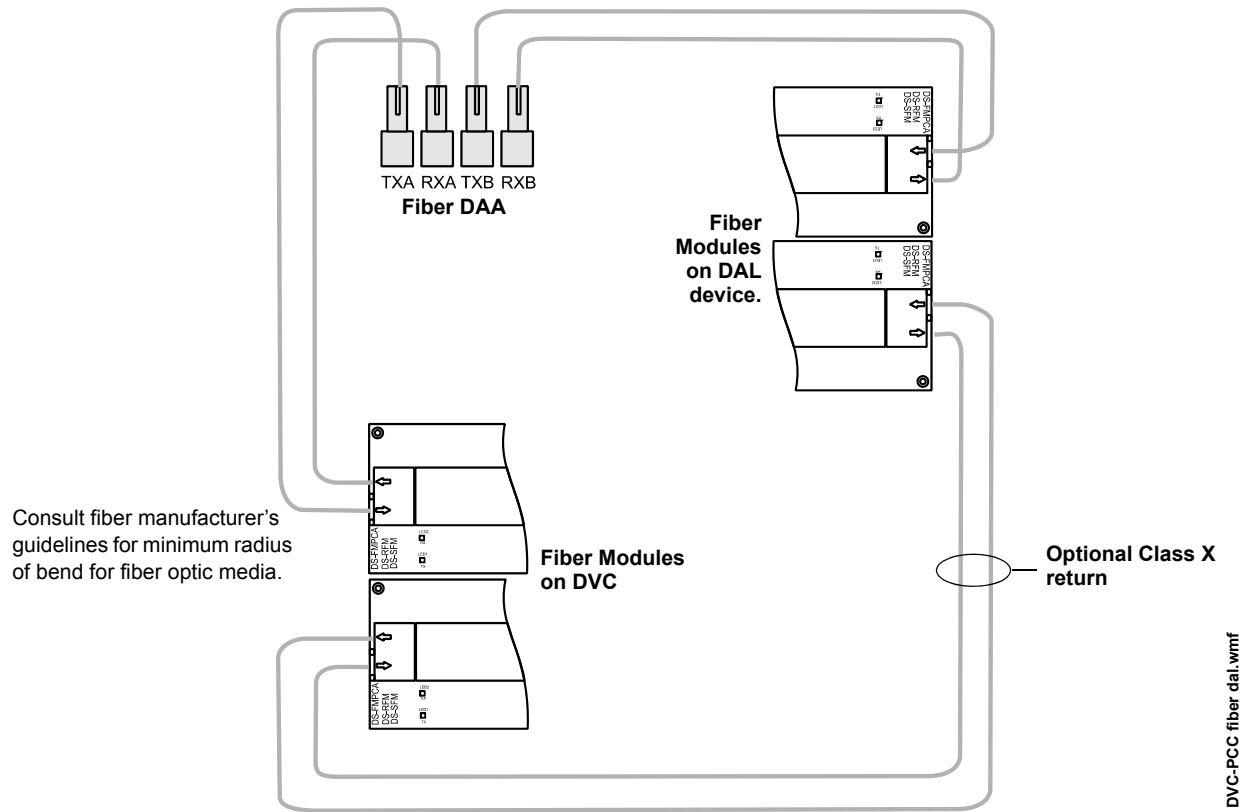

Figure 2.16 Fiber DAL Connections



NOTE: Class B configuration must be installed in accordance with the requirements for survivability from attack by fire in the National Fire Alarm Code, NFPA 72.

2.10.4 FFT Connectivity

FFT Riser (TB13)

The Firefighter’s Telephone Riser connections (TB13) provide for the use of Firefighter’s Telephones (FFTs) on an analog network. They are a means of connecting various FFT telephone control modules and devices, such as FTM-1 modules, AFAWS, FPJ, or RPJ-1, to the DVC. The FFT riser may be wired in NFPA Class A (4-Wire) or Class B (2-Wire) configuration. VeriFire Tools must be used to select 4-Wire or 2-Wire for trouble supervision. A 3.9k 1/2 watt end-of-line resistor (included, P/N R-3.9K) is required for 2-wire configurations.

Firefighter’s Telephones must be connected to FTM-1 telephone modules.

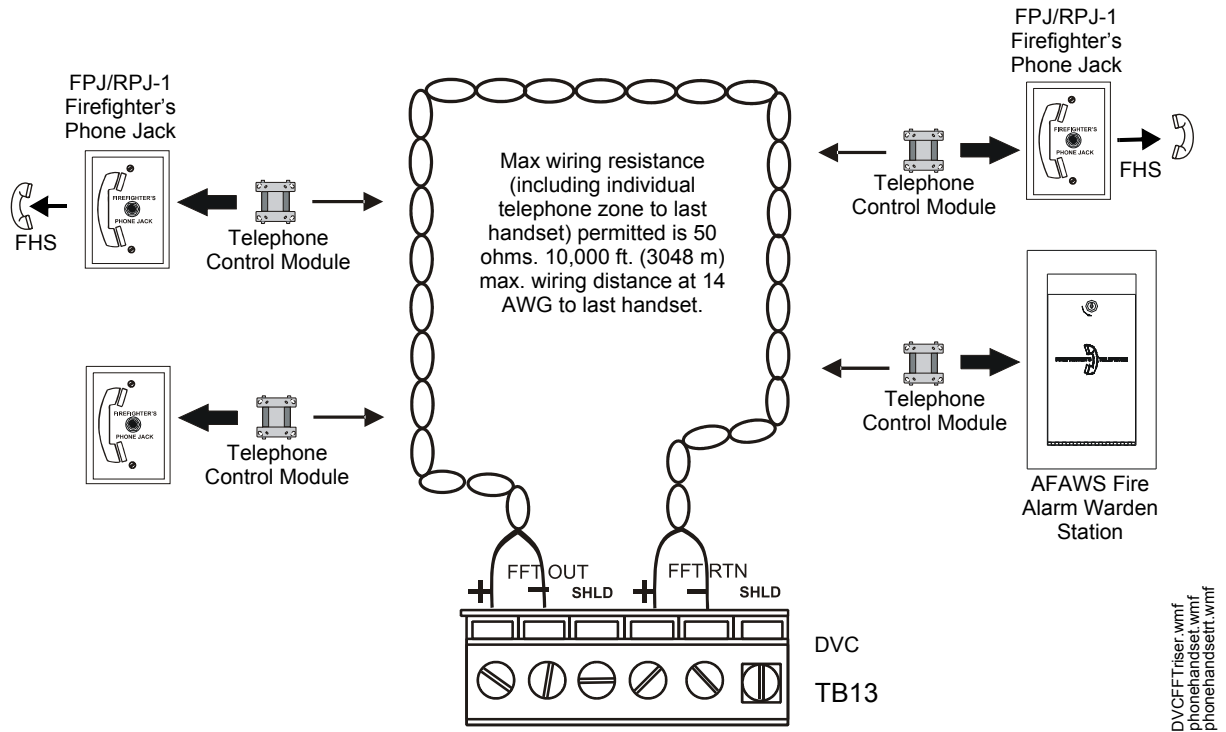
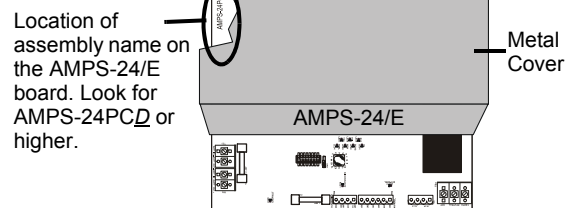

Figure 2.17 FFT Riser on DVC Board (4-Wire Example)

An FHS firefighter handset may be used with the phone jacks in Figure 2.17. For a description of the Firefighter’s Telephone network operation, refer to “FFT Paging” on page 76. An FFT on this riser may be used for paging locally or to a standard or high-speed Noti•Fire•Net.



NOTE: For supervision of the FFT riser when using an AMPS-24/E to power the DVC, use assembly AMPS-24PCD or higher of the AMPS-24/E. Do not use AMPS-24PCC or less. The power supply’s metal cover must be removed to view the board’s assembly name. Refer to the illustration at right for location. All assemblies labeled AMPS-K2 may be used for supervision.



NOTE: Digital audio software Version 2.0 and above does not support FFT risers on first release DAA boards, which are marked “PCA”. Refer to the DAA appendix in the DAA2/DAX manual for how to determine board type. Check VeriFire or an appropriate network display to determine the software version. This note does not apply to the DAA2, DAX and DS-DB.

2.10.5 Auxiliary Inputs A and B

The DVC provides two analog audio connections. Auxiliary inputs allow external audio sources to be used as audio inputs for the DVC.

Auxiliary Input A

Auxiliary Input A (AUXA) provides a high-fidelity connection to external paging sources and provides a connection to common audio appliances such as a radio, CD player, MP3/MP4 player, portable audio device, tape deck, or to a telephone paging source. It can be used for background music. Two-channel stereo signals are changed to monophonic signals. AHJ approval required.

VeriFire Tools programming determines if signal supervision of AUXA is enabled or disabled, and also determines whether the sound is standard or high-fidelity.

18 AWG twisted unshielded pair recommended.

Signal strength from low-level analog audio input:
1.6VP-P max. for each when both AUXA L and AUXA R are used.
3.2VP-P max. for one when only one (AUXA L or AUXA R) is used.

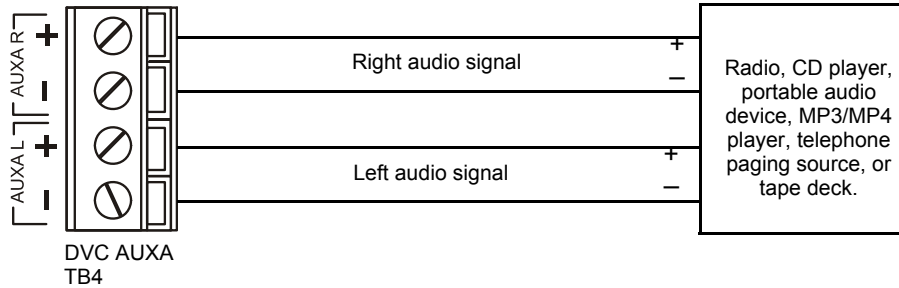

Stereo input shown. Monophonic input may connect to either AUXA R or AUXA L.

Figure 2.18 AUXA Auxiliary Audio Input

DVCAUXAtb4.wmf

Auxiliary Input B

Auxiliary Input B (AUXB) is provided to accept low-level analog audio (AMG-style audio) input at 12Vp-p nominal, 15Vp-p max. The messages are then transmitted out to speaker circuits as designated by programming.

VeriFire Tools programming determines if signal supervision of AUXB is enabled, and also determines whether the sound is standard or high-quality.

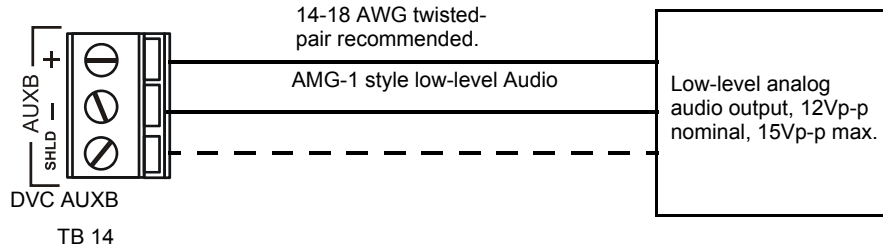

Figure 2.19 AUXB Auxiliary Audio Input

DVCAUXBtb14.wmf

2.10.6 Network Connection (NUP) Ports

NUP Ports A and B (J1 and J2 on the DVC board) are functionally the same, and either may be used to connect the DVC to:

- either NUP port (not both) on a network communications module,
- to an NFS2-3030 or NFS2-640, or to an NCA-2 if it is connected to an NFS2-640, to VeriFire Tools.

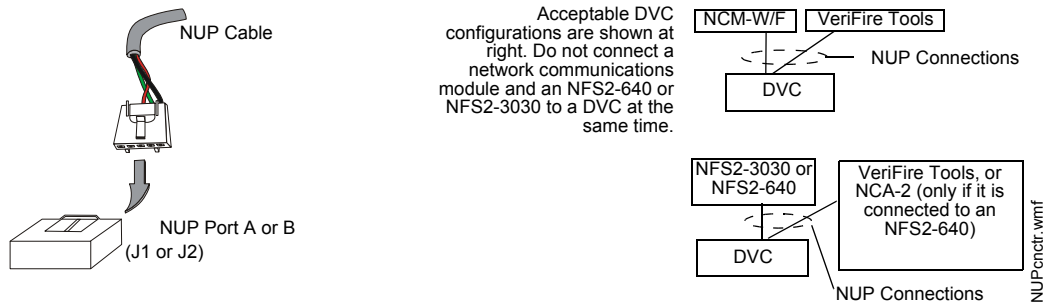

Figure 2.20 DVC NUP Connections and Configurations

NUPcntr.wmf

NUP cables are included with NCM and HS-NCM modules and also with the DVC.

2.10.7 USB Ports

The USB ports (USB A, J3, and USB B, J4) are functionally the same, and either may be used to connect the DVC to a PC with VeriFire Tools to perform uploads and downloads.

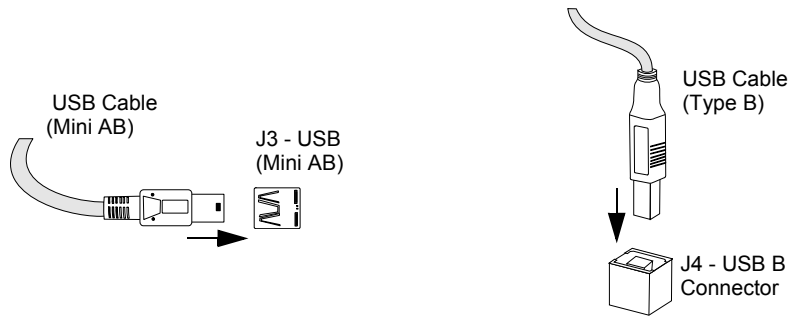

Figure 2.21 DVC USB Port Connections

DVC mini_AB USB cbl.wmf
DVC B USB cbl.wmf

2.10.8 Push-to-Talk Indicator

The DVC PTT contacts (TB10) provide contact closure when the push-to-talk (PTT) button on the DVC local microphone (CMIC-1) is pressed. These contacts may be used to activate a monitor module, which can in turn be used to initiate a CBE event based on a microphone PTT press.



NOTE: As of DVC software 4.0 or higher, push-to-talk operands are available for use in DVC logic equations. (See Section 3.11 on page 66 for information.) When logic equations are built using a PTT operand to activate CBE, an SLC module is not necessary.

2.10.9 RM-1 Remote Microphone Interface

The Remote Microphone Interface (RMI, TB9) accommodates one RM-1 Series microphone, providing the DVC with remote paging and/or message override capabilities. The RM-1 may be used for paging locally or to a standard or high-speed Noti•Fire•Net. Refer to Figure 2.22 for DVC connection to a single RM-1.

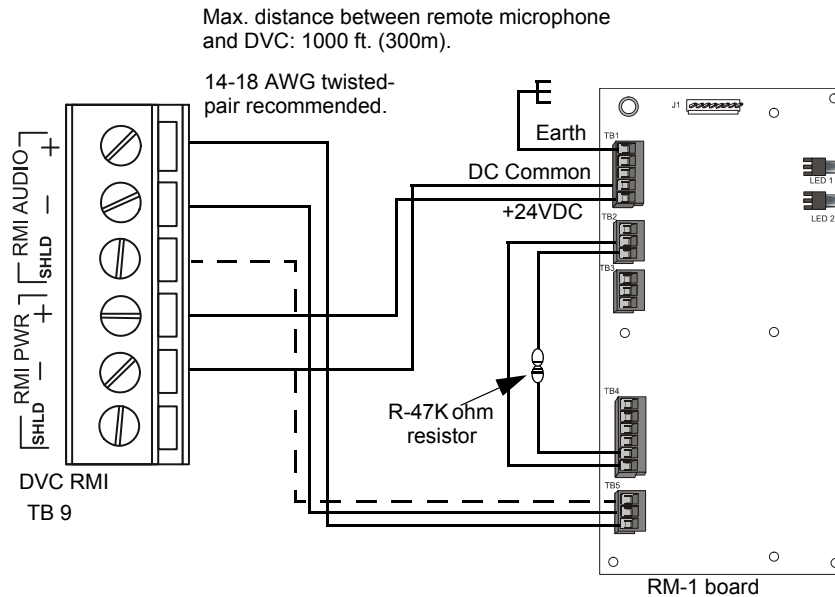

Figure 2.22 RM-1 to DVC Connections

DVCRM1tb9.wmf
RM1board.wmf

See the RM-1 Series document for more information on this product. Refer only to single-microphone applications: multiples (e.g. daisy-chaining) are not compatible with the DVC.

An “RM-1 PTT” point is available in logic equation programming. Refer to “Logic Equations Branch” on page 66.

2.10.10 MIC-1 Local Microphone Interface

The local microphone interface (J5) is a plug-in connection for the cable on the MIC-1 microphone, which provides the DVC with paging capabilities. The microphone connection will be monitored for continuity when MIC-1 is enabled in VeriFire Tools.

The DVC PTT contacts (see Section 2.10.8 on page 36) and related logic equation(s) will activate when the microphone's push-to-talk button is pressed.

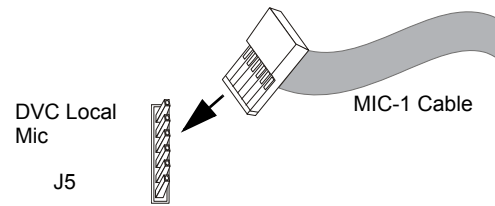

DVCtoMICcxj5.wmf

Figure 2.23 MIC-1 Microphone Interface

2.10.11 TELH-1 Local Phone Interface

The local phone interface (J8) is a plug-in connection for the cable on the TELH-1 Firefighter's Telephone handset. This provides a connection to the analog FFT riser, and gives the DVC paging capabilities (selectable from the DVC-KD and utilization of the phone's push-to-talk button). The TELH-1 will be supervised for short or open circuit conditions when "Local FFT" is selected in VeriFire Tools.

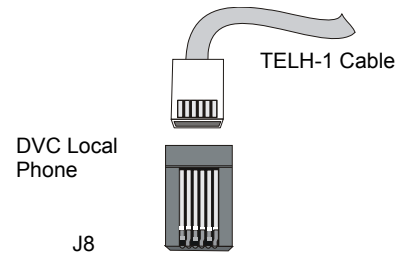

DVCtoLocalPhoneJ8.wmf

Figure 2.24 TELH-1 Telephone Interface

2.10.12 Analog Audio Outputs (DVC-AO)

The DVC-AO option board generates low-level analog audio messages that may be used as inputs to AA-Series audio amplifier and ACT-4 audio coupling transformers.

Figure 2.25 through Figure 2.26 give examples of how the DVC-AO may be used. For more complete wiring instructions on the AA-Series amplifiers and Audio Coupling Transformers, refer to the documentation that accompanies these devices.

2.10.13 Wiring Fault Testing

Test wire-to-wire faults with 0 (zero) ohm impedance.

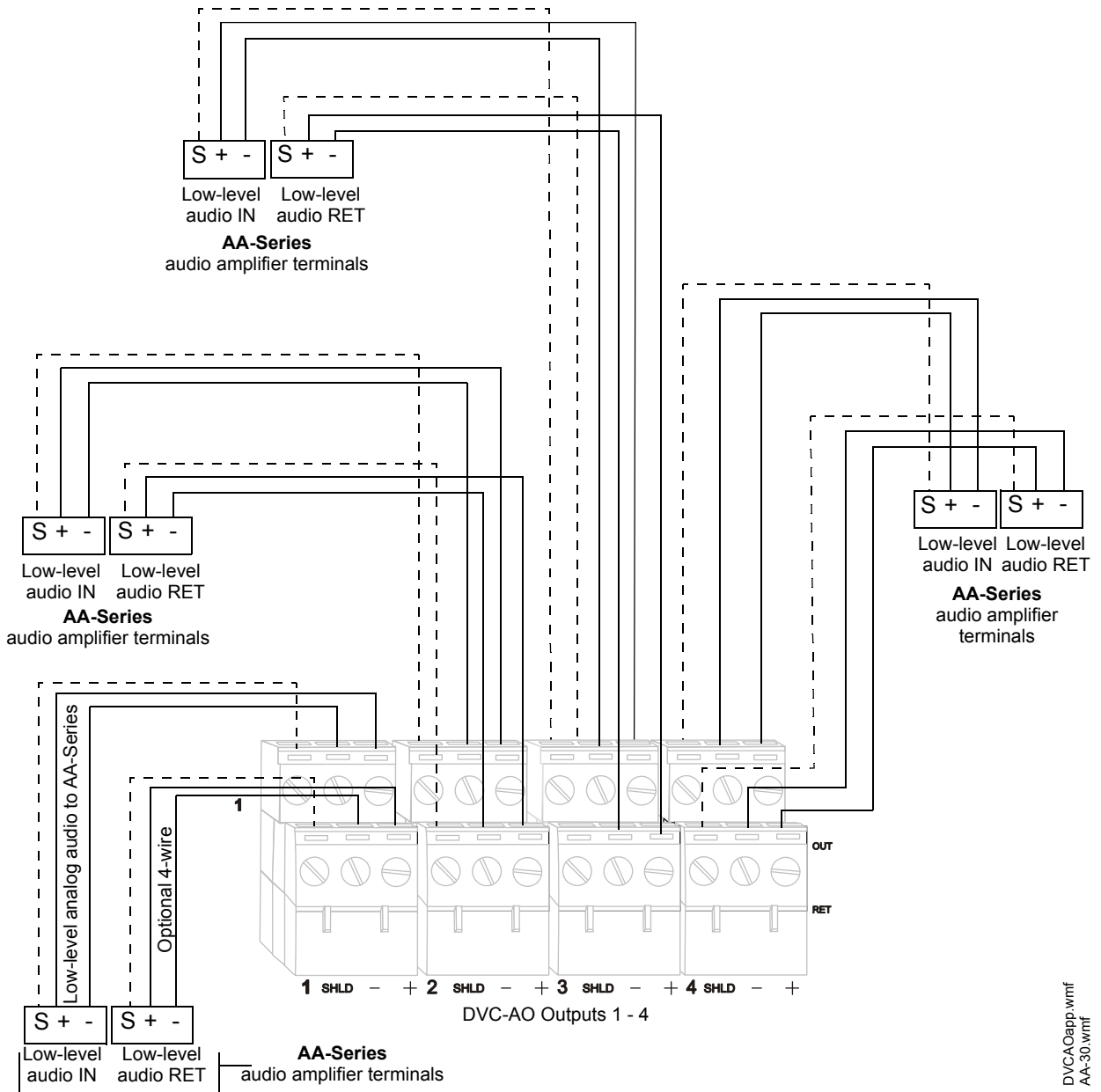

Figure 2.25 Wiring the DVC-AO Board, Example A

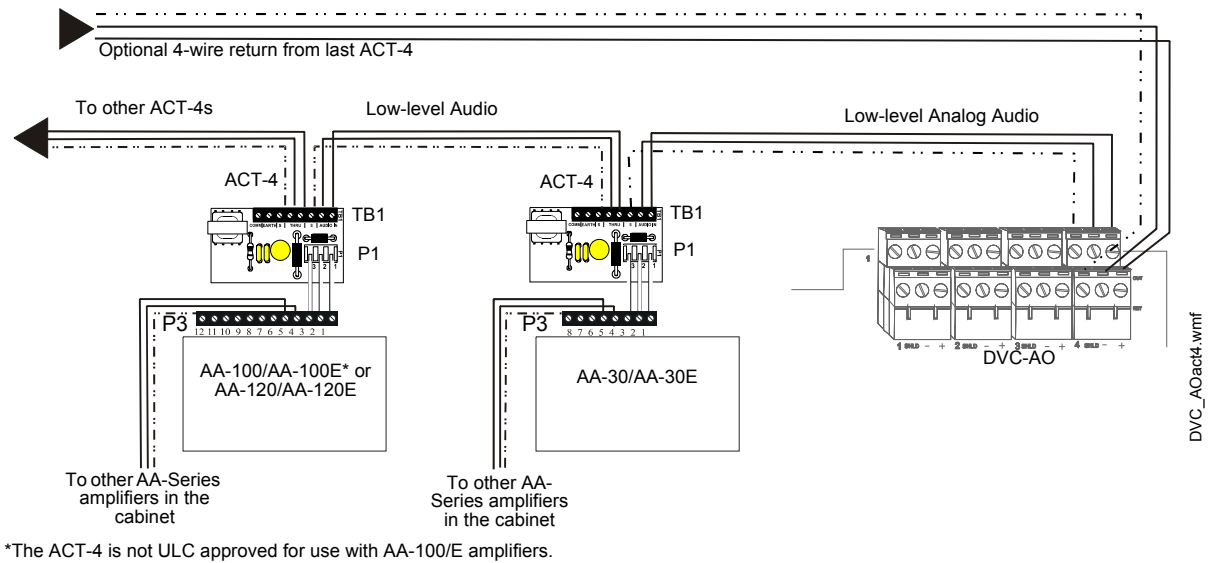

Figure 2.26 Wiring the DVC-AO Board, Example B

2.10.14 UL Power-limited (Class 2) Wiring Requirements

DVC circuit wiring is all power-limited (Class 2), and it may enter or exit the cabinet together. However, when the DVC is in a cabinet with another product that has non-power-limited wiring, all of the DVC's circuitry must be separated from any non-power-limited circuitry in the cabinet. All power-limited circuit wiring must remain at least 0.25 inches (6.35 mm) from any non-power-limited circuit wiring. All power-limited and non-power-limited circuit wiring must enter and exit the cabinet through different knockout and/or conduits. Install tie wraps and adhesive squares to secure the wiring.

2.11 Replacement of NVRAM Memory-Backup Battery

The DVC board has a snap-in lithium battery that provides backup of the DVC's on-board memory during power loss. Refer to Figure 1.3 on page 17 for the location. The expected shelf-life for this battery is 10+ years. However, if battery connections are damaged or the battery does lose power, a system trouble message will appear: "NVRAM BATT TROUBLE". A new battery (P/N 31005, SGS Thompson M4T32BR12SH1) must be purchased and installed to replace the old.

To replace the battery:

1. Power down the system.
2. Remove any boards in front of the DVC board to provide access to the battery.
3. Use your fingers to carefully pull the battery off the board.
4. Align and push the new battery into the same space. The dot in one corner of the battery should align as indicated in Figure 1.3 on page 17.
5. Replace the front boards and power up the system.
6. Reset the time at Noti•Fire•Net's master clock so the DVC will immediately regain its clock function. If this step is skipped, the DVC will send out network messages with an invalid time stamp until it regains its clock function within an hour communicating on Noti•Fire•Net.

Section 3: DVC Configuration and Programming

3.1 Setting the Configuration Switches

3.1.1 Piezo (Switch 5)

The DVC has a piezo that arrives from the factory enabled. It will sound during a DVC trouble event, and may be acknowledged at a network workstation, NCA-2, or an NFS2-3030 or NFS2-640 that is not on Noti•Fire•Net. However, it will resound if another trouble event occurs within the DVC. The piezo can be disabled or enabled using SW5. Disabling the piezo causes a trouble to be sent to the panel or network annunciator and/or network workstation.

SW5 in enabled position.



DVC\piezoenabl.wmf

To disable, push the switch towards DIS.

Figure 3.1 Piezo Enable/Disable

3.1.2 4WIRE (Switch 8)

The FFT riser may be wired in a (2-wire) configuration. For installations, enable the switch. For Class B, disable the switch.

VeriFire Tools programming must be set the same as this switch.

SW8 in enabled position.

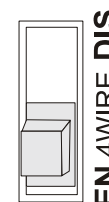

To disable, push the switch towards DIS.

Figure 3.2 4WIRE Enable/Disable

3.2 Programming

3.2.1 Overview

Most DVC programming is done in VeriFire Tools and downloaded to the DVC.

The one exception is when the DVC is acting as an audio command center: In this case, volume control settings for the DVC originate at the NFS2-3030 or NCA-2. This programming can be done at the panel itself or through VeriFire Tools. Refer to the point programming sections of these manuals for more information, as well as to the annunciator programming sections for relevant ACS programming instructions.

All other programming is stored in the DVC itself and is done in VeriFire Tools. Digital Audio Loop (DAL) device programming can be routed through the DVC, allowing code to be loaded simultaneously into multiple devices.

3.2.2 Programming in VeriFire Tools

The current version of DVC can be programmed with VeriFire Tools 8.00 and higher or VeriFire Tools 7.10. This manual describes programming with VeriFire Tools version 8.00. (See “VeriFire Tools Programming Interface” on page 41.) Earlier versions of VeriFire Tools will differ in options and appearance. Older versions of the DVC can be programmed with the current edition of VeriFire Tools. Download VeriFire Tools and the optional DVC Audio Files from esd.notifier.com.

In VeriFire Tools version 8.00 and higher, click on the Edit Session tree for a DVC node to view the programming options:

- General Settings
 - General Settings tab (See “General Settings Tab” on page 44.)
 - Program Settings tab (See “General Settings Branch, Program Settings Tab” on page 46.)
- DAL Mapping (See “DAL Mapping” on page 50.)
- KD Mapping (See “KD Mapping DVC-KD” on page 48.)
- General Zones (See “DVC General Zones” on page 50.)
- Audio Settings (See “Audio Message Programming Overview” on page 57.)
- DVC Inputs (See “DVC Inputs Branch” on page 59.)
- PAM Settings (See “Prioritized Audio Matrix (PAM) Programming Overview” on page 62.)
- Logic Equations (See “Logic Equations Branch” on page 66.)

These branches are opened up together, grouped as “System Programming”: General Settings, Program Settings, KD Mapping, and General Zones. Note that the DAL Mapping branch is not part of the System Programming tab, although it appears before KD Mapping in the Edit Session Tree. This manual keeps the System Programming tab group together; DAL Mapping is discussed after General Zones. Note that PAM points must be programmed after audio messages and logic equations have been created.

DVC Special Function Zones

DVC provides special functions zones which can be referenced by (but not changed by) VeriFire Tools. See “Special Function Zones” on page 68.

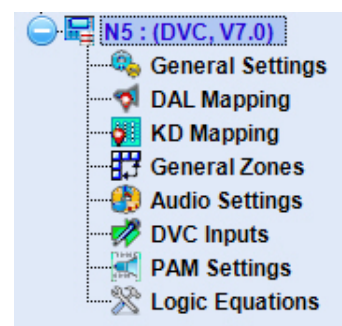

VeriFire Tools Utilities

VeriFire Tools provides utilities to validate programs and generate reports. This information is also available in the online help file; press F1 when within the program.

- See “Program Validation” on page 69.
- See “Reports” on page 69.

3.2.3 Special Applications

Mass Notification Systems

DVC can be programmed for use in a Mass Notification system. Requirements and specific instructions for such a system are provided in the Mass Notification System manual, P/N LS10063-000NF-E. The steps for creating and programming MN Active Tone and Fire Active Tone are in the Mass Notification System manual.

Releasing Systems

In the event that a releasing notification device is co-located in the same area as notification devices for fire or mass notification, the audio system shall incorporate the state of the releasing system into the activation programming (i.e. logic equation programming) to ensure the audio system is inactive in the areas of releasing during an active releasing event.

Live Voice Instructions

If a previously initiated recorded message is interrupted by live voice instructions, upon releasing of the microphone, the previously initiated recorded messages to the selected notification zones shall have the capability of not resuming play automatically. A logic equation with a delay function with a local microphone argument must be present such that after the live voice page is completed and released, a prerecorded audio file with no audio shall be played.

3.2.4 VeriFire Tools Programming Interface

VeriFire Tools 8.00 and higher has a streamlined programming interface. The following features are used to program the DVC. The VeriFire Tools help file contains additional tips, tricks, and training materials. Open the help file by pressing F1 inside VeriFire Tools, or by clicking the Help File icon on the Back-Stage screen (located where earlier editions of Windows put the File Menu).

Project Files - All nodes of a networked system are now maintained within one VeriFire Tools project. Projects can be created new or from existing node databases, and additional existing nodes can be imported into the project.

From the “Startup Services” tab, click <Create Project> and select “New Project”, “New Project from Existing Database”, or “Import Database.”

To import data from an existing fire alarm system, create a project, then log onto the existing network and upload the node information into VeriFire Tools.

To log on, physically connect your VeriFire Tools computer to the local or remote network as described in the VeriFire Tools Installation Sheet. From the Startup Services tab, select the type of network connection used by your active system. Log onto one node, click “Upload/Download”, and follow the on-screen instructions. See your VeriFire Tools helpfile for screenshots and examples.

Assigning a node - The DVC node number is assigned when the node is added to the project. The DVC must *always* be assigned a unique node address, even when used with a standalone FACP. That is, when used with a standalone FACP, the DVC must be assigned a node number different from that FACP. This number can be reassigned; see the VeriFire Tools online help file.

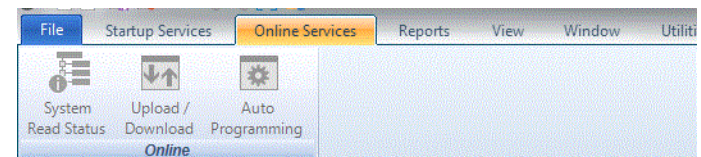
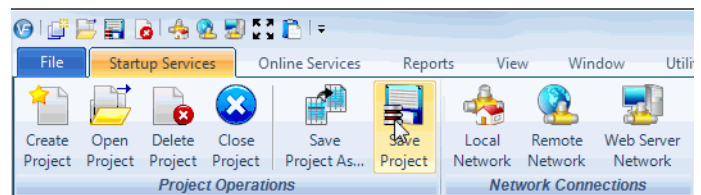

Edit Session Tree - The Edit Session Tree displays links to all project nodes in outline format. Click on the “+” sign to expand the individual node; this displays to programming branches. Click on a branch to open it for viewing and editing. Right-click on the project name at the top to add a new node or expand all branches. Right-click on a branch to see context-sensitive menu choices.

The Online Session Tree is an equivalent screen area that displays information for the system (local or remote network) that VeriFire Tools is currently logged into. To log onto a node, right-click the node’s branch in the Online Session Tree.

Data-entry grid - VeriFire Tools calls its spreadsheet-style interface the “data-entry grid”.

Open an Edit Session Tree branch to view and edit grids of programming information. For each row, data can be entered or selected from a list of drop-down options. Fields that display in gray are unavailable due to current settings or missing information, or are display-only.

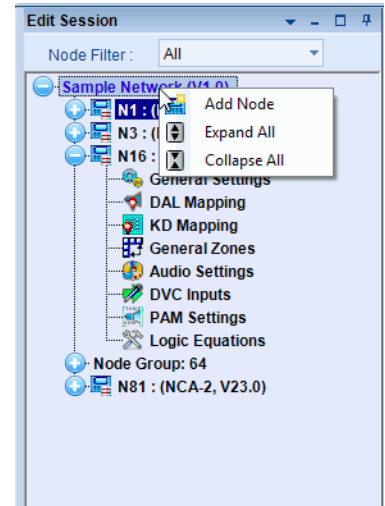

Click into fields with the mouse to enter data, or move around the grid with the tab and arrow keys. Single-clicking into a cell will highlight it ("Highlight/Focus mode"). Double-click to select the cell's contents ("Edit mode") or simply start typing to overwrite it with new contents. Users who prefer to work without a mouse should refer to the Help File for keyboard shortcut instructions. Sort the information in a column by clicking on its header row.

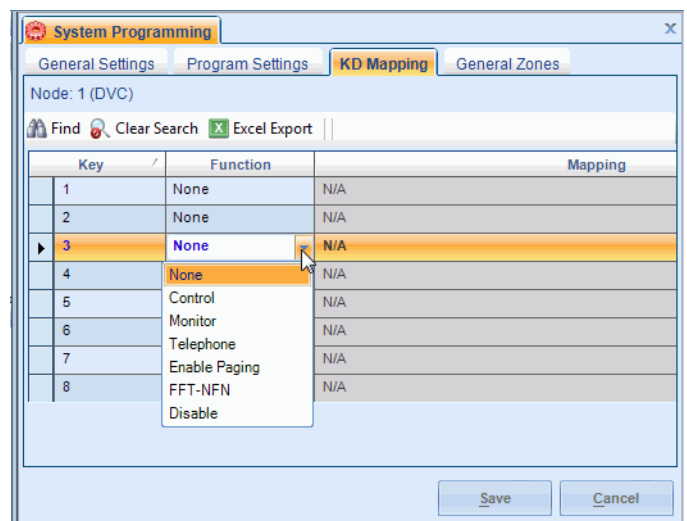

In some branches, clicking into a row with an installed device will open the bottom half of the screen to display detailed options for that specific device.

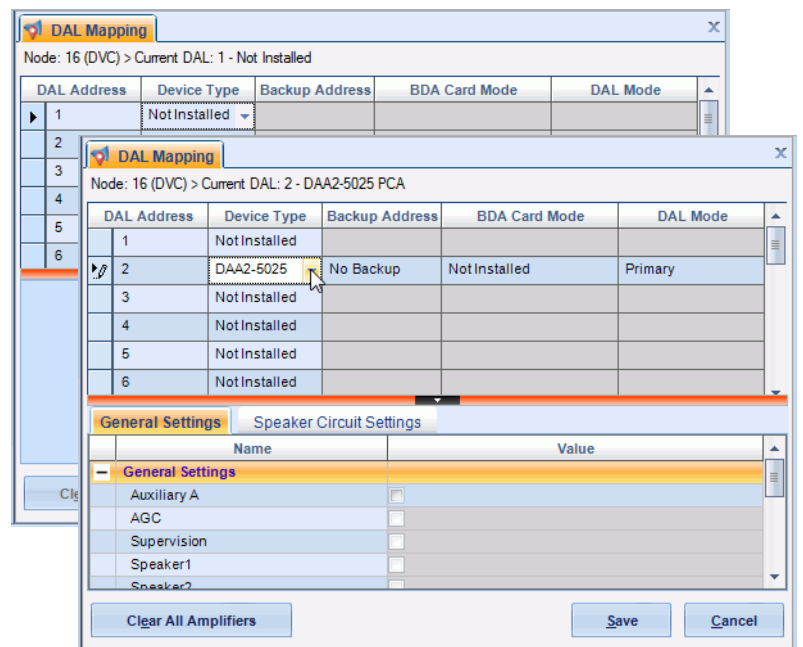

In other branches, each row is expandable to display options specific to the device or programming feature listed in that row.

Save - Click <Save> at the bottom of a screen to save changes made to one programming branch. Click <Save> on the Startup Services tab or on the Quick Access Toolbar to save the entire project.

Undo changes - Click <Cancel> at the bottom of a screen to undo programming changes to one screen.

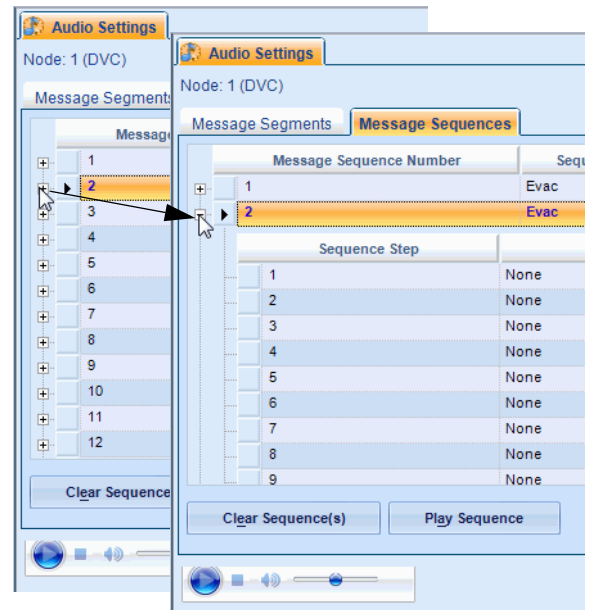

3.3 General Settings Branch

Settings for the DVC itself can be accessed from this branch of the Edit Session tree. It will bring up General Settings tab, the Program Settings tab, the DVC-KD tab, and General Zones tab. DAL Mapping has been given its own Edit Session Tree branch and must be clicked separately to open in an independent tab.

In VeriFire Tools 8.00 and higher, click on the General Settings Branch of the Edit Session Tree to bring up these tabs. The General Settings tab groups several sub-sections that can be expanded or hidden. Some “General” Screens from VeriFire Tools 7.10 and lower have been separated out to take full advantage of the new interface. See Section 3.3.2, “General Settings Branch, Program Settings Tab” and Section 3.6, “DAL Mapping”.

3.3.1 General Settings Tab

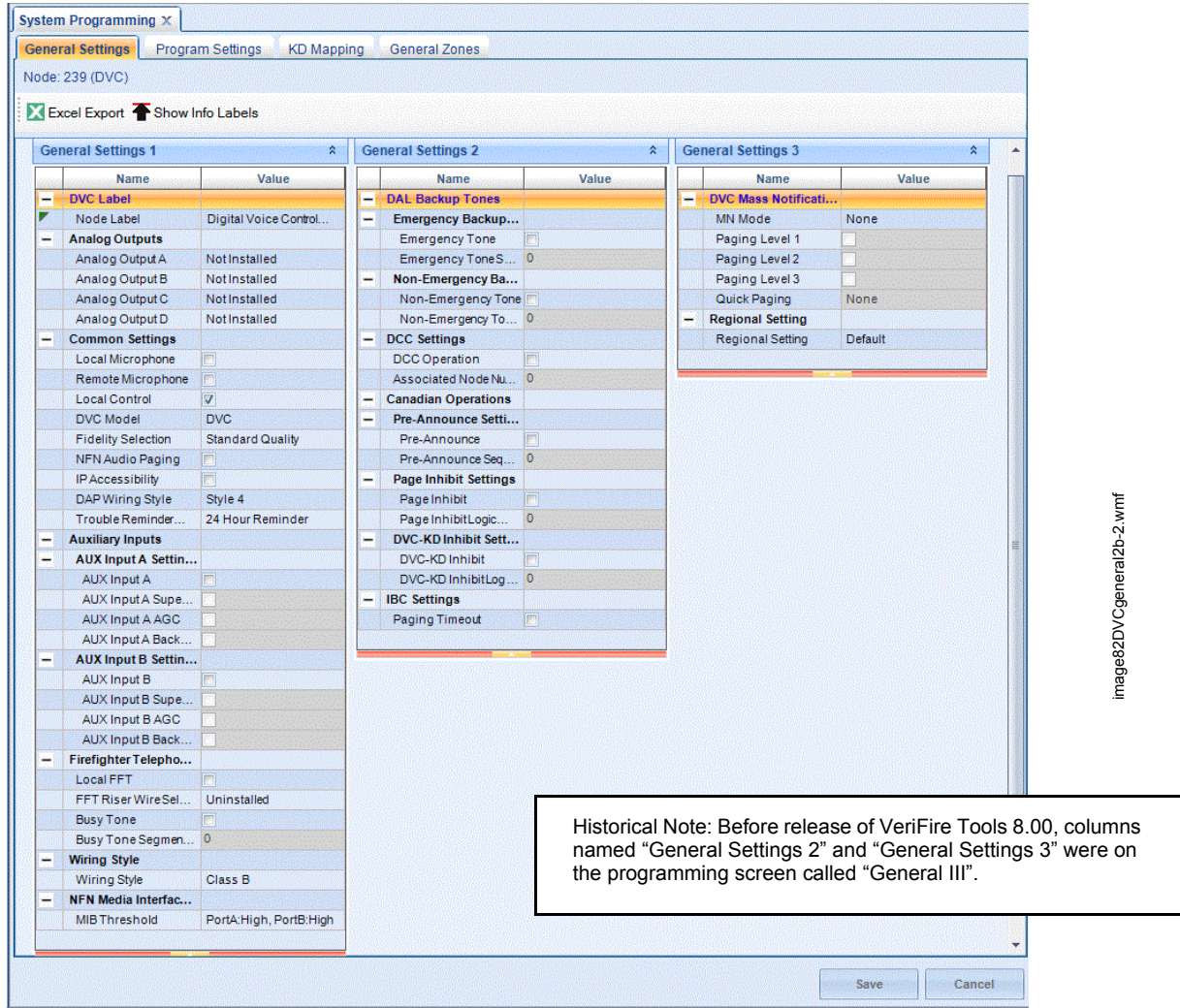

Figure 3.3 DVC General Settings

General Settings Tab, Column 1

DVC Label: Enter the network node label for this DVC. You may enter up to 40 characters.

Analog Outputs: Describe the configuration for DVC’s Analog Output A, B, C, D (“Not Installed”,) on the DVC. Requires DVC-AO. “Installed” analog outputs will be represented in the PAM columns as output circuits for DVC-0. (PAM programming is described in “Prioritized Audio Matrix (PAM) Programming Overview” on page 62.)

Common Settings: The following settings are grouped together: Local Microphone, Remote Microphone, Local Control, DVC Model (DVC), Fidelity Selection (Standard Quality), NFN Audio Paging, IP Accessibility, DAP Wiring Style (Class B, Class X), Trouble Reminder Options.

- **Local/Remote Microphone:** Select to install the local and/or remote microphone. See the RM-1 Series document for more information on the remote microphone.
- **Local Control:** Select to enable local DVC control of the following DVC-KD keys: ALL CALL, PAGE ACTIVE EVAC AREAS, PAGE ACTIVE ALERT AREAS, PAGE INACTIVE AREAS, and ENABLE TELEPHONE PAGE.
- **DVC Model:** Choose from the drop-down menu to indicate if the DVC is the standard (DVC) or an extended memory (DVC-EM) version. The DVC-EM Extended Memory versions contain up to 32 minutes of standard quality (11.025 kHz sampling rate, 8 bit μ -law, mono) audio storage, or 4 minutes of high quality (44.1 kHz sampling rate, 16 bit PCM, mono).
- **Fidelity Selection:** Choose the desired audio quality (standard or high). A message saved as high quality requires more storage space than the same message saved as standard quality.
 - Standard quality - 11.025 kHz sampling rate, 8 bit μ -law, mono.

- High quality - 44.1 kHz sampling rate, 16 bit PCM, mono..

**NOTE:** The DVC uses:

- 8 audio channels on the DAL (digital audio loop) with the standard quality audio setting.
- 1 audio channel on the DAL with the high quality audio setting.
- 1 audio channel on a standard or high-speed Noti•Fire•Net

**CAUTION: DVC MODEL/FIDELITY SELECTION**

DO NOT MODIFY SETTINGS FOR “DVC MODEL” OR FIDELITY PROGRAMMING ONCE PAM POINTS AND AUDIO MESSAGES ARE INSTALLED. CHANGING THESE SELECTIONS WILL *DELETE* ALL PAM POINTS AND AUDIO MESSAGING INFORMATION.

- **NFN Audio Paging:** Check this box if network paging from any of the DVC’s live inputs to outputs on other DVCs is desired. Live inputs can include the DVC’s local microphone, the microphone attached to DVC-RPU, an RM-1 remote microphone, a Firefighter’s Telephone, or a live input from an AUXA or AUXB connection. A check here creates the “Network” column in the PAM. (See “Prioritized Audio Matrix (PAM) Programming Overview” on page 62.) If this box is not checked, network paging is disabled.



NOTE: For a standard Noti•Fire•Net, the number of nodes allowed is limited to 54 when NFN Audio Paging is selected. This limitation does not apply to a high-speed Noti•Fire•Net.

- **IP Accessibility:** Check to enable IP Access. This setting allows the disabling/enabling of commands, downloads and programming from a Remote Network. To initiate downloads to the DVC, go to the Online Services ribbon menu and click on Upload/Download. (VeriFire Tools must be connected to the network for the icon to be selectable.) DVC downloads have a six-hour window to be completed.



NOTE: Use of the IP Accessibility feature is subject to the approval of the local AHJ.

- **DAP Wiring Style:** Select Class B or Class X.
- **Trouble Reminder Options:** Check to enable a 24 hour reminder.

Auxiliary Inputs. This groups AUX Input A Settings and Aux Input B Settings.

- **AUX Input A and AUX Input B:** Check to install input(s).
- **Aux Input A/B Supervision:** Check to enable supervision of the specified inputs.
- **Aux Input A/B AGC:** Check to enable automatic gain control. This feature will smooth an incoming signal to produce a consistent sound.



NOTE: Enable automatic gain control only in applications where the input is a voice input, such as from a telephone paging system. Do not enable automatic gain control when using background music.

- **Aux Input A/B Background Music:** Check if the input is to be used for background music. Background music will be disabled during AC Fail and will not play out of a DAA or DAA2 that has a battery charge rate greater than 1 amp (Battery size is greater than 26 AH and batteries are being charged).

Firefighter’s Telephone Settings. The following settings are grouped together: Local FFT, FFT Riser Wire Selection, Busy Tone, and Busy Tone Segment Numbering.

- **Local FFT:** Select when a local TELH-1 FFT is installed. The connection will be supervised for open and short circuit conditions.
- **FFT Riser Wire Selection** (Uninstalled, Installed, 2 Wire, Installed, 4 Wire.) Select to describe the . Switch 8 (Refer to “4WIRE (Switch 8)” on page 40) must be set the same as this selection. Select UNINSTALLED if there is no FFT riser installed.
- **Busy Tone:** Check to select a message segment that will play when there is still no telephone circuit available after the phone has rung several times. The SEGMENT selection box will light up when this field is checked. This selection will apply to all FFT risers on the DAL (Digital Audio Loop). If BUSY TONE is not selected, the phone will continue to ring until answered. Refer to Appendix B on page 76 for an example.
- **Busy Tone Segment Numbering:** Select a segment that will play while the line is busy. This segment plus the emergency/non-emergency segments have a limit of 106 seconds for standard fidelity and for high fidelity.

Wiring Style: Select according to your network’s configuration CLASS B or CLASS X. Refer to standard and high-speed Noti•Fire•Net Manuals for more information.

NFN Media Interface Settings: Set MIB Threshold to establish tolerable noise thresholds for network communications. Select PortA:High, PortB:High. PortA:Low, PortB:High. PortA:Low, PortB:Low. PortA:Low, PortB:Low. Not applicable for high-speed Noti•Fire•Net Systems.

General Settings Tab, Column 2

DAL Backup Tones: Defines the message segments (usually tones) that will be broadcast during the loss of DAP communication. These backup messages are stored within each DAA/DAA2/DAX/DS-DB for activation when communication is lost. These tones, in addition to the “Busy Tone”, are limited to 106 seconds combined.

- **Emergency Backup Tones:** The message segment selected will broadcast when a DAL device’s alarm bus is active and the unit is offline to the DVC. (Emergency Tone, Emergency Tone Segment)
- **Non-Emergency:** The message segment selected will broadcast when the DAL device’s alarm bus is inactive and the unit is offline to the DVC. This message will not broadcast during AC failure. (Non-emergency Tone, Non-emergency Tone Segment)

DCC Settings: The DCC Settings box appears when the MN Mode type is “None” in the DVC Mass Notification Settings. It defines whether the DVC will participate in DCC operation for paging functions, and if so, which network control node it will be associated with. See Section 4.3, “Display and Control Center (DCC)” as well as the glossary.

- **DCC Operation:** Check to enable DCC participation.
- **Associated Node Number:** Map a DCC-designated DVC to a network control node through which it will be able to assert network control for network paging purposes.

Canadian Operations:

- **Pre-Announce, Pre-Announce Sequence:** To enable the Pre-Announce feature, click Pre-Announce, then select an audio sequence. The selected sequence will play before all pages from the DVC’s MIC-1 local microphone, and the TELH-1 local telephone. The “Pre-Announce” LED on the DVC-KD will light for the duration of the pre-announce.
- **Page Inhibit, Page Inhibit Logic Equations:** The Page Inhibit selection applies to the ALL CALL, PAGE ACTIVE EVAC AREAS, PAGE ACTIVE ALERT AREAS, and PAGE INACTIVE AREAS buttons on the DVC-KD. To enable, check the box and select a logic equation that will inhibit the page while the logic equation is active. The “Page Inhibit” LED on the DVC-KD will light for the duration of the page inhibit.
- **DVC-KD Inhibit, DVC-KD Inhibit Logic:** The DVC-KD Inhibit selection applies to the 24 buttons on the right half of the DVC-KD. To enable, check the box and select a logic equation that inhibits the DVC-KD while the logic equation is active.

IBC Settings, Paging Timeout: Check this box to allow an interruption of an automatic EVAC or ALERT message by three minutes of live paging. Paging will be shut off automatically after three minutes.

General Settings Tab, Column 3

DVC Mass Notification Settings: This section defines what node the DVC is associated with to form a mass notification station. The LOC, ACU and CCS settings determine what inputs are used by the three ALL CALL buttons, and what inputs can be used for DVC-KD programming. See the Mass Notification System manual, P/N LS10063-000NF-E, for instructions on correctly configuring a Mass Notification system.

MN Mode: (Default: NONE) When changing from “None” to any of the three Mass Notification modes, the DVC will add and rename the appropriate “live” inputs from their original meaning, and display the changed meanings in a dialog box.

- **None:** The DVC will not act in MN mode. This mode is only for DVCs that are part of a network with no mass notification.
- **LOC, ACU, CCS:** The DVC will act in the mass notification mode selected. The LOC, ACU, and CCS settings determine what inputs are used by the three All Call buttons, and what inputs can be used in DVC-KD programming.
 - The All Call buttons in the second column of the DVC-KD will have Level buttons (see Appendix E, “DVC MN Modes”, on page 90).
 - The microphone will use MN inputs (see Table 3.4, “First 14 Default Input Priorities (DVC Configured for Mass Notification),” on page 62).
- **Subsidiary:** Use this setting only when the DVC is present on an MN network, but is not part of an ACU, LOC, or CCS.



NOTE: DVC’s that are part of a mass notification network must be assigned a mode of LOC, ACU, CCS, or Subsidiary. DVC’s that are not part of a mass notification network must be assigned the mode NONE.

- **Paging Level 1:** Check this box to enable ALL CALL paging from the top button in column two of the DVC-KD. (Refer to “DVC Inputs Branch” on page 59.) Paging Level 1 has the highest priority of the paging levels. Not applicable in “None” Mode.
- **Paging Level 2:** Check this box to enable ALL CALL paging from the second button down in column two of the DVC-KD. (Refer to “DVC Inputs Branch” on page 59.) Paging Level 2 has a priority less than Paging Level 1, and greater than Paging Level 3. Not applicable in “None” Mode.
- **Paging Level 3:** Check this box to enable ALL CALL paging from the third button down in column two of the DVC-KD. (Refer to “DVC Inputs Branch” on page 59.) Paging Level 3 has a lesser priority than Paging Levels 1 and 2. Not applicable in “None” Mode.



NOTE: One, two, or all three Paging Levels may be checked when the MN Mode is ACU, LOC or CCS. MN paging levels are not available when the MN Mode is Subsidiary.

- **Quick Paging:** When Quick Paging is enabled, a DVC-RPU button push is not required for paging. Pressing the push-to-talk button on the microphone is sufficient to initiate an ALL CALL page at the Paging Level programmed (1, 2, or 3).

Regional Setting: Change from “Default” to “Canada”, to enable Canadian Regional settings on the DVC.

- **Canada:** When the DVC’s Regional Setting is set to Canada, an Alarm Signal activation will generate a System Trouble indicating Alarm Signal Active.

3.3.2 General Settings Branch, Program Settings Tab

All Call Mapping, Special Paging Functions

The interface for setting All call Mapping and Special Paging Functions is similar: check the node number(s) that should respond to conditions configured elsewhere in VeriFire Tools. Nodes should be other DVCs or a panel with SLC speaker points. Buttons at the top enable the user to clear all nodes, and to select all nodes.

ALL CALL paging - When the Aok, ILL CALL button is pressed on the current DVC’s DVC-KD, all checked nodes will receive and broadcast the ALL CALL message.

SPECIAL PAGING FUNCTIONS - This screen configures the following DVC-KD buttons: PAGE ACTIVE EVAC AREAS, PAGE ACTIVE ALERT AREAS, and PAGE INACTIVE AREAS.

- In multi-channel applications where audio message sequences are saved in standard fidelity format, these special functions can override the message sequence types they describe (EVAC or ALERT messages that are active), or can page to areas where no messages are active.
- In single-channel applications, where audio message sequences are saved in high fidelity format, these pages are disabled and the column will be grayed out.
- In mass notification applications, Special Paging Functions are not available. MN Mode must be set to “None” in order to use Special Paging Functions.

Starting with VeriFire Tools 6.0, alarm bus programming is performed using logic equations. For “Alarm Bus Maps” see “Logic Equations Branch” on page 66.

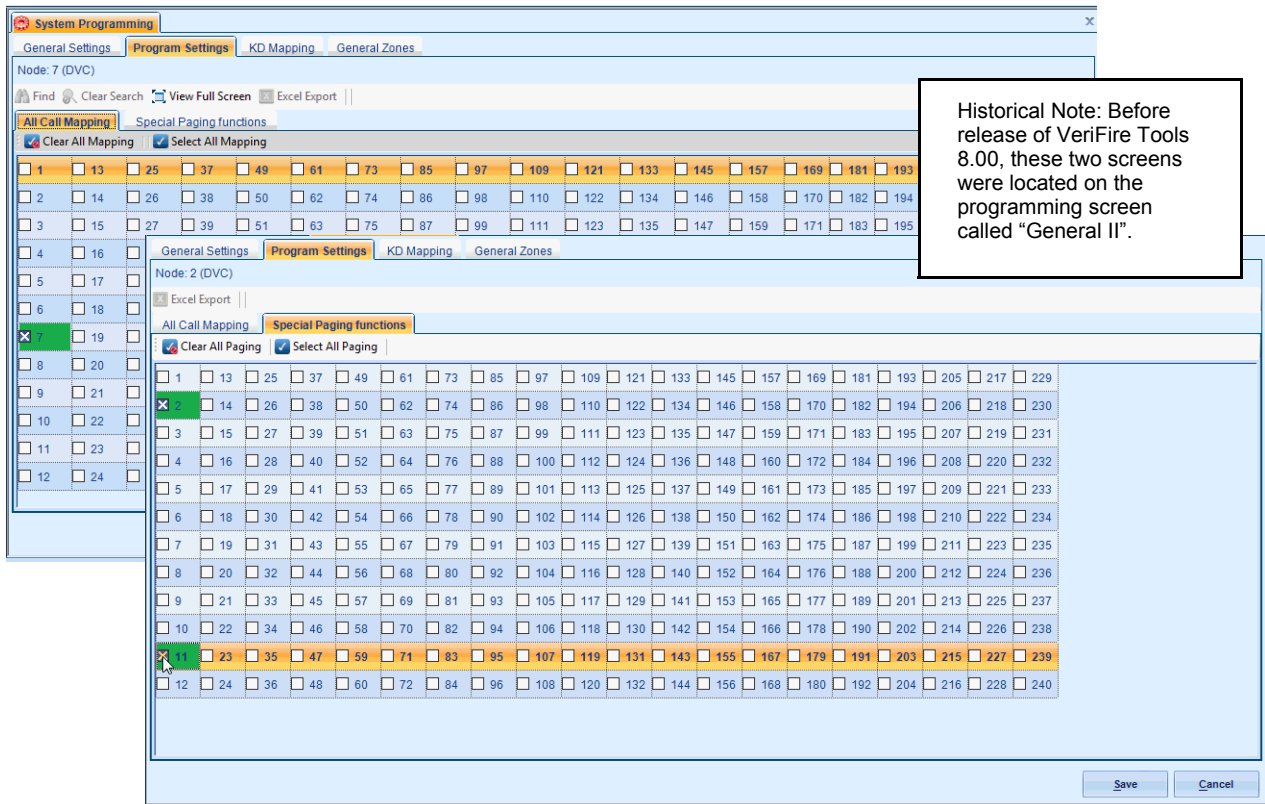

Figure 3.4 Program Settings: All Call Mapping, Special Paging Functions

3.4 KD Mapping DVC-KD

Program the user-defined keys on the DVC-KD. Map a function to a node, module, detector, panel circuit point, zone, or PAM point. If the DVC-RPU keyboard has already been programmed, those settings can be cloned by clicking <Clone From RPU>. Single keys can be duplicated by copy/paste, as with copy/paste as in other VeriFire Tools data-entry grids.

The screenshot shows the 'System Programming' window with the 'KD Mapping' tab selected. The window title is 'Node: 96 (DVC)'. Below the title bar, there are search and export options: 'Find', 'Clear Search', and 'Excel Export'. The main area contains a table with 18 rows, each representing a key. The columns are 'Key', 'Function', and 'Mapping'. The 'Function' column lists various control functions, and the 'Mapping' column lists specific node identifiers. A 'Clone From RPU' button is located at the bottom right of the table area, along with 'Save' and 'Cancel' buttons.

Key	Function	Mapping
1	None	N/A
2	Control	I9A22S1
3	Control	I13A22S1
4	Control	I3A22S1,I3A22S3
5	Control	I9A22S1,I9A22S3
6	Control	I13A22S1,I13A22S3
7	Control	I3A22S1,I3A22S3
8	Control	I9A22S1,I9A22S3
9	Control	I13A22S1,I13A22S3
10	Control	I3A22S1,I3A22S3
11	Control	I9A22S1,I9A22S3
12	None	N/A
13	Control	I3A22S3
14	Control	I9A22S3
15	Control	I13A22S3
16	None	N/A
17	None	N/A
18	None	N/A

Figure 3.5 DVC System Programming Service – DVC-KD

DVC-KD Field Definitions

KEY -There are 24 user-defined keys on a DVC-KD. Refer to Figure 4.1 on page 70 for the numbering format.

FUNCTION - Select from None, Control, Monitor, Telephone, All Call, Page Evac, Page Alert, Page Inactive, Enable Paging, FFT-NFN, Disable.

- Control - select to program a button to activate paging or control points.
- Monitor - select to program a button that will monitor a point for activity.
- Telephone - select to program a button for a phone connection local to the DVC's DAL (digital audio loop).
- All Call - select to program nodes to the "ALL CALL" button, which initiates ALL CALL paging.
- Page Evac - select to program nodes to the "PAGE ACTIVE EVAC AREAS" button, which initiates paging to active evacuation areas in the assigned nodes.
- Page Alert - select to program nodes to the "PAGE ACTIVE ALERT AREAS" button, which initiates paging to active alert areas in the assigned nodes.
- Page Inactive - select to program nodes to the "PAGE INACTIVE AREAS" button, which initiates paging to inactive areas in the assigned nodes.
- Enable Paging - select to program a button to enable paging from AUX A, AUX B, or RM-1.
- FFT-NFN - select to program a button to broadcast from a Firefighter's Telephone over Noti•Fire•Net. The FFT-NFN function is used for FFT communication between two DVCs. Refer to Appendix B.2.2 on page 77.
- Disable - select to create a button that will disable a single local or network DAL device speaker circuit point, or all the speaker circuits on a DAL device.
- None - Default. The key is not programmed.

MAPPING - Enter the points, nodes or zones to be mapped. VeriFire Tools provides Source Syntax for each Function type; drag over the orange bar to display it on the right side of the screen. The syntax for each type of entry is also in Table 3.1 below.

- Monitor function - Map one source address. Must be a detector, module, panel or bell circuit point, zone, logic zone, trouble zone, releasing zone, special zone, PAM point or speaker point.
- Control function - Map up to 8 points. Source must be a module, panel or bell circuit point, PAM point or general zone.
- Telephone function -
 - map one telephone control module's address, or
 - map to one FFT riser that has no telephone control modules Use the address NxxxAyyT, where N = node number, yy = the DAL device address [1 - 32].
- All Call, Page Evac, Page Alert, and Page Inactive functions for the user-programmable keys - Map up to 8 network nodes. These nodes do not have to be any of the nodes selected to function with the All Call, Page Active EVAC areas, Page Active ALERT area, or Page INACTIVE area buttons on the left side of the DVC-KD.
- Enable Paging function - AUX A or AUX B will be selectable from a pull-down menu when this function is chosen.
- FFT-NFN function -
 - map two DVC network nodes. A telephone control module is optional, or...
 - map two DVC network nodes and one DAL device FFT riser that has no installed telephone control modules.
- Disable function -
 - map to one local speaker circuit point.
 - map to one network speaker circuit point.
 - map to disable all speaker circuits on a local DAL device.
 - map to disable all speaker circuits on a network DAL device.

Type of Entry	Syntax*	Explanation
detector	LxxDyyy	xx = panel loop number, yyy = detector SLC address
module	LxxMyyy	xx = panel loop number, yyy = module SLC address
panel circuit	Px.y	x = panel circuit address, y = panel circuit point address
bell circuit	Bx	x = bell circuit address
zone	Zx	x = zone number
logic zone	ZLx	x = logic zone number
trouble zone	ZTx	x = trouble zone number
releasing zone	ZRx	x = releasing zone number
special zone	ZFx	x = special zone number
PAM point	lxxxxAyySz	x = input number, y = DAL device address, z = speaker circuit address
speaker point	AxxSy	xx = DAL device address, y = speaker circuit address
Node	Nxxx	xxx = Noti•Fire•Net. node address
FFT riser with no installed telephone control modules	AxT	x = DAL device address where the FFT riser resides
(disable) all speaker points	AAxxD	xx = address of DAL device where all speakers will be disabled
*NOTE: Add Nxxx, where xxx = network node number, at the beginning of the syntax entry if the entry is for a point on a different network node.		

Table 3.1 Point Mapping Syntax

3.5 DVC General Zones

DVC general zones may be monitored from anywhere in the system to annunciate active paging from a location. The DVC supports up to 500 user-programmed general zones (Z1 - Z500).

These user-programmed zones can be activated by up to 1044 PAM points. This gives the user the option of creating general zones for each PAM point: these zones will activate when the PAM point activates. Using these general zones in logic equations enables further granularity of the type of page being performed.

DVC general zone labels prefill with their Zone number. Labels can be customized using the data-entry grid shown in Figure 3.6. Text can be copied from other Windows programs and pasted into these fields. Labels may be up to 20 characters.

The following General Zones are reserved for specific use and are not programmable:

- **General Alarm Zone Z0** may be used as a general activation zone that will activate when any PAM point activates. DVC General Zones can also be controlled on/off by the DVC-KD or ACS points. Local Zone, Label (“0” is reserved for General Alarm; the rest prefill with zone address e.g. Zone Z001.) Note that General Zone Z0 can be relabelled, but its function is reserved.
- **General Zones 501-533** activate whenever microphone paging is active from a DVC, DVC-RPU, or ONYXWorks.
- **General Zones 501-532** activate with paging from DVC-RPU addresses 1-32.
- **General Zone 533** activates with paging from the DVC, or ONYXWorks.

Note: General zones & Logic equations must be set up before PAM Programming can reference them. (See “Prioritized Audio Matrix (PAM) Programming Overview” on page 62.)

For a related topic, see Appendix 3.12, “Special Function Zones”, on page 68.

Local Zone	Label
0	General Alarm
1	Zone Z001
2	Zone Z002
3	Zone Z003
4	Zone Z004
5	Zone Z005
6	Zone Z006
7	Zone Z007
8	Zone Z008
9	Zone Z009
10	Zone Z010
11	Zone Z011
12	Zone Z012
13	Zone Z013
14	Zone Z014
15	Zone Z015
16	Zone Z016
17	Zone Z017
18	Zone Z018
19	Zone Z019
20	Zone Z020

Figure 3.6 DVC General Zones

3.6 DAL Mapping

3.6.1 Overview

Use the DAL Mapping branch to assign addresses to Digital Audio Loop (DAL) devices. For each DAL Address, enter the Device Type to be installed by selecting it from the drop-down box as shown in Figure 3.7. After entering Device Type, fill out the relevant fields for that address: Backup Address, BDA Card Mode (Dual Channel, Backup), and DAL Mode (Primary or Backup). The “Backup address” field of a Primary device must reference a DAL device that is configured as Backup.

When an address with an installed Device Type is selected, the bottom half of the screen will display appropriate options for that Device Type. Device settings are organized by tabs: General Settings, Speaker Circuit Settings, Low-Level Outputs, Groups, and RPU KD.

This section lists the options available to particular device types, followed by definitions of those options and the fields where VeriFire Tools stores their definitions.

- See “DAA/DAX/DAA2 Amplifier Programming Options” on page 51.
- See “DAA/DAX/DAA2 Amplifier Field Definitions” on page 52.
- See “DS-DB Programming Options” on page 53.
- See “DS-DB Field Definitions” on page 54.
- See “DVC-RPU Programming Options” on page 55.
- See “DVC-RPU Field Definitions” on page 55.

When fields are unavailable, that field will be grayed out. This can be because a particular field is not available to a product, or because of programming prerequisites. For example, the BDA Card Mode field will be grayed out on an original DAA series audio amplifiers because those did not offer BDA Card Mode. As a second example, “backup address” field will be grayed out for a DAL device that is configured as a backup. Before the Device Type is assigned, all fields are grayed out.



NOTE: Press “Clear All Amplifiers” to erase all DAL Mapping for this DVC. All DAL addresses will be cleared back to default.

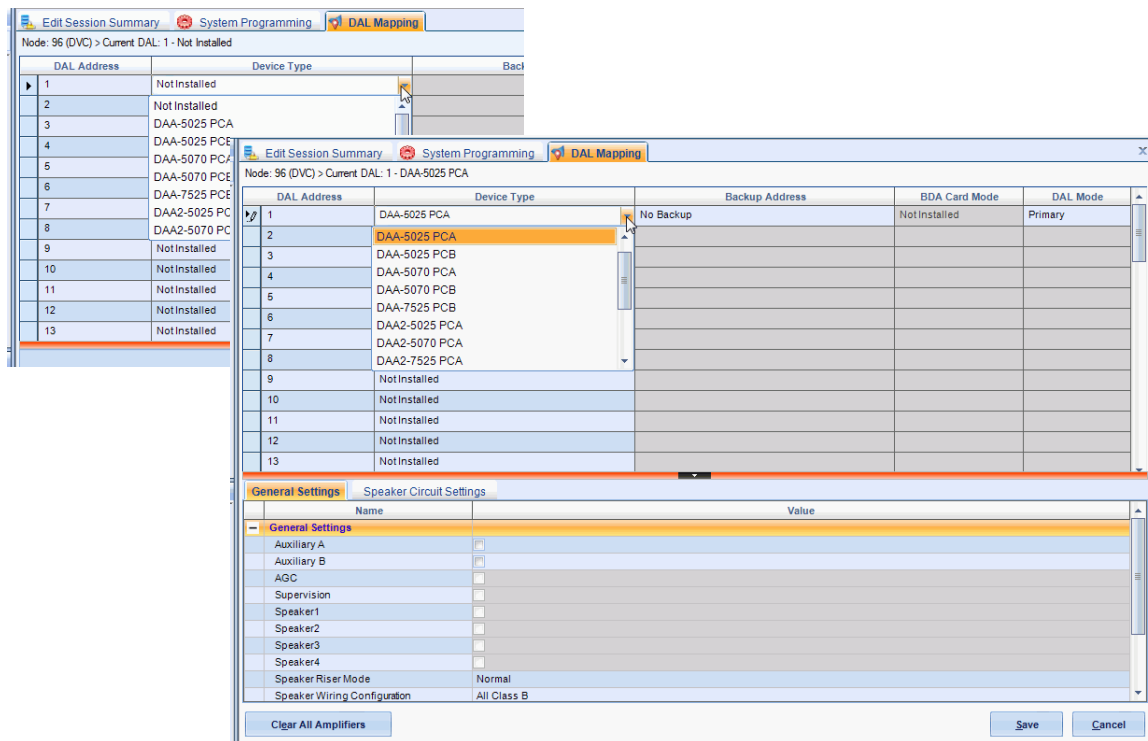

Figure 3.7 DAL Mapping - Install a Specific Device to View and Program Its Settings

3.6.2 DAA/DAX/DAA2 Amplifier Programming Options

Use the following services to program associated amplifiers and speaker points with individual settings.

DAA-5025 PCA

- **General Settings Tab** - Auxiliary A, Auxiliary B, AGC, Supervision, Speaker1 - Speaker4, Speaker Riser Mode, Speaker Wiring Configuration, Battery Size, Disable Charger.
- **Speaker Circuit Settings** - Speaker Circuit 1 - 4, Custom Label, Extended Label.

DAA-5025 PCB

- **General Settings** - Auxiliary A, Auxiliary B, AGC, Supervision, Speaker1 - Speaker4, Speaker Riser Mode, Speaker Wiring Configuration, Battery Size, Disable Charger, Install FTM Module, FFT Riser Wire Selection.
- **Speaker Circuit Settings** - Speaker Circuit 1 - 4, Custom Label, Extended Label.

DAA-5070 PCA

- **General Settings** - Auxiliary A, Auxiliary B, AGC, Supervision, Speaker1 - Speaker4, Speaker Riser Mode, Speaker Wiring Configuration, Battery Size, Disable Charger.
- **Speaker Circuit Settings** - Speaker Circuit 1 - 4, Custom Label, Extended Label.

DAA-5070 PCB

- **General Settings** - Auxiliary A, Auxiliary B, AGC, Supervision, Speaker1 - Speaker4, Speaker Riser Mode, Speaker Wiring Configuration, Battery Size, Disable Charger, FTM Module, FFT Riser Wire Selection.
- **Speaker Circuit Settings** - Speaker Circuit 1 - 4, Custom Label, Extended Label.

DAA-7525 PCB

- **General Settings** - Auxiliary A, Auxiliary B, AGC, Supervision, Speaker1 - Speaker4, Speaker Riser Mode, Speaker Wiring Configuration, Install FTM Module, FFT Riser Wire Selection.
- **Speaker Circuit Settings** - Speaker Circuit 1 - 4, Custom Label, Extended Label.

DAA2-5025 PCA

- **General Settings** - Auxiliary A, AGC, Supervision, Speaker1 - Speaker4, Speaker Riser Mode, Speaker Wiring Configuration, DAL Group, BDA Group, Install RM1, Send RM1 Audio to DVC, Local RM1 Mode, Battery Size, Install Disable Charger, Install FTM Module, FFT Riser Wire Selection.
- **Speaker Circuit Settings** - Speaker Circuit 1 - 4, Custom Label, Extended Label.

DAA2-5070 PCA

- **General Settings** - Auxiliary A, AGC, Supervision, Speaker1 - Speaker4, Speaker Riser Mode, Speaker Wiring Configuration, DAL Group, BDA Group, Install RM1, Send RM1 Audio to DVC, Local RM1 Mode, Battery Size, Disable Charger, Install FTM Module, FFT Riser Wire Selection.
- **Speaker Circuit Settings** - Speaker Circuit 1 - 4, Custom Label, Extended Label.

DAA2-7525 PCA

- **General Settings** - Auxiliary A, AGC, Supervision, Speaker1 - Speaker4, Speaker Riser Mode, Speaker Wiring Configuration, DAL Group, BDA Group, Install RM1, Send RM1 Audio to DVC, Local RM1 Mode, Disable Charger, Battery Size, Install FTM Module, FFT Riser Wire Selection.
- **Speaker Circuit Settings** - Speaker Circuit 1 - 4, Custom Label, Extended Label.

DAX-3525 PCA

- **General Settings** - Speaker Riser Mode, Disable Charger, Speaker Wiring Configuration, Battery Size.
- **Speaker Circuit Settings** - Speaker Circuit 1 - 2, Custom Label, Extended Label.

DAX-3570 PCA

- **General Settings** - Speaker Riser Mode, Disable Charger, Speaker Wiring Configuration, Battery Size.
- **Speaker Circuit Settings** - Speaker Circuit 1 - 2, Custom Label, Extended Label.

DAX-5025 PCA

- **General Settings** - Speaker Riser Mode, Speaker Wiring Configuration.
- **Speaker Circuit Settings** - Speaker Circuit 1 - 2, Custom Label, Extended Label.

DAX-5070 PCA

- **General Settings** - Speaker Riser Mode, Speaker Wiring Configuration
- **Speaker Circuit Settings** - Speaker Circuit 1 - 2, Custom Label, Extended Label.

3.6.3 DAA/DAX/DAA2 Amplifier Field Definitions**Basic DAL Device Settings (Top Half of DAL Mapping Screen)****■ Amplifier settings**

- **AMPLIFIER MODE** – Select PRIMARY or BACKUP from the pull-down menu.
- **BDA CARD MODE** – Select NOT INSTALLED, DUAL CHANNEL, or BACKUP from the pull-down menu.
- **BACKUP AMPLIFIER ADDRESS** – Select the backup amplifier address, or NO BACKUP, from the pull-down menu. Only backup amplifiers with matching BDA, speaker, group and riser mode settings will be available.

General Settings Tab (Bottom Half of DAL Mapping Screen)**■ Firefighter's Telephone Settings - These fields do not display for DAA PCA boards or DAX boards.**

- **FFT RISER WIRE SELECTION** –
 - For DAA amplifiers - Select the wiring style (INSTALLED 2 WIRE or INSTALLED 4 WIRE) according to the configuration of the analog network. Select UNINSTALLED when the FFT riser is not installed.
 - For DAA2 or DS-DB - Select INSTALLED or UNINSTALLED to indicate if there is a riser or not.
- **INSTALL FTM MODULES** – Check this box if there are FTMs installed on the FFT riser with its Firefighter's Telephones. When this box is not checked, the address NxxxAyyT - where N = node number, yy = the DAL device address (1 - 32) - can be used for FFT for mapping.

■ Auxiliary Input Source - These fields do not display for DAX boards.

- **AUXILIARY A** – Check to install the AUXA analog input into the database.
- **AUXILIARY B** - Check to install the AUXB analog input into the database (DAA-PCB and DAA-PCA boards only).
- **AGC** – Check to enable automatic gain control. This feature will smooth an incoming signal to produce a consistent sound.



NOTE: Enable automatic gain control only in applications where the input is a voice input, such as from a telephone paging system. Do not enable automatic gain control when using background music.

- **SUPERVISION** – Check to enable or disable supervision of the auxiliary input.
- **AUXILIARY ACTIVATION** – Check which speaker circuits on the amplifier will be activated when amplifying data from the AUX input.

■ Speaker Settings

- **SPEAKER RISER MODE** – A DAL device can have only one Riser Mode type: the riser mode type chosen will be applied to all speaker circuits on the DAL device. Backup amplifiers must be programmed with the same riser mode type as the primary amplifiers. Select from the following DAL device Riser Mode types.
 - NORMAL - Select NORMAL when the DAL device will not be used for riser or room isolator applications.

- **RISER TO ADDITIONAL AMPLIFIERS** - Select when the DAL device's output will be used with one or more audio coupling transformers to drive additional amplifiers. (ACT-70 for 70V amplifiers, ACT-25 for 25V amplifiers.) Only one DAL device speaker circuit may be installed when operating in this mode. This selection provides a 200 Hz tone that is required for additional analog amplifiers. Refer to the DAA2/DAX manual.
- **RISER TO ADDITIONAL CONTROL MODULES** - Select when the DAL device's output will be routed to multiple speaker circuits using control modules. In this mode, the DAL device will provide speaker circuit supervision only when idle. Only one DAL device speaker circuit may be installed when operating in this mode. Do not use background music on the DAL device in this mode. Refer to the DAA2/DAX manual.
- **RSM OR AIM SERIES ROOM ISOLATORS** - Select when connecting these modules to the DAL device's speaker circuits. Only one DAL device speaker circuit may be installed when operating in this mode. These modules are for specific Canadian applications. Refer to the DAA2/DAX manual for more information.
- **CIM OR CSM SERIES ROOM ISOLATORS** - Select when connecting these modules to the DAL device's speaker circuits. Only one DAL device speaker circuit may be installed when operating in this mode. Do not use background music on the DAL device in this mode. These modules are for specific Canadian applications. Refer to the DAA2/DAX manual for more information.
- **SPEAKER WIRING CONFIGURATION** – Make selection to program speaker circuit pairs (1/2 and 3/4.) Selection must reflect physical configuration. Refer to the DAA2/DAX manual for wiring illustrations.



CAUTION: DO NOT CHANGE WIRING CONFIGURATION AFTER SPEAKER CIRCUIT PROGRAMMING.

CHANGING THE WIRING CLASS CONFIGURATION AFTER THE SPEAKER CIRCUITS HAVE BEEN PROGRAMMED MAY DELETE THE SPEAKER CIRCUIT PROGRAMMING! (SEE PAGE 53.)

■ Power Supply Settings

- **BATTERY SIZE: AMP HOURS** - Select the size of the secondary power source.
- **DISABLE CHARGER** - Check to disable the charger on this DAL device. The charger should be disabled if this DAL device is sharing batteries with at least one other DAL device, and is not the DAL device that will supply the battery charging. See the battery sharing section for the appropriate device.

■ Group Settings (DAA2 only)

Groups consist of a collection of speaker circuits on a DAA2 with one or more amplifiers assigned to it. Refer to Appendix D, “Audio Groups”, on page 86 for more information.

- **AMPLIFIER GROUP** - Select the group number for the digital amplifier.
- **BDA GROUP** - Select the group number for the BDA amplifier.

■ RM-1 Settings (DAA2 only)

- **INSTALL RM-1** - Check this box to activate the circuit for supervision.
- **SEND RM-1 AUDIO TO DVC** - Check this box to make the audio available as a source to the I1038 PAM row. The first DAA2 with an active push-to-talk (PTT) will be the source. Once the PTT is released, the next active PTT will become the source of the audio. Any DAA2's RM-1 audio takes priority over the DVC RM-1 audio.
- **LOCAL RM-1 MODE** - This setting will adjust the priority of the RM-1 to its own DAA2.
 - **Override DVC audio to all speakers** - Select to make the local RM-1 the highest priority audio source for that DAA2.
 - **Override DVC background music to all speakers** - Select to give the RM-1 priority over background music only.
 - **Let DVC control RM-1 routing** - With this selection, the RM-1 will not perform any local paging, and the DVC PAM controls where the RM-1 audio is routed.

If the DAA2 loses communication with the DVC, the local RM-1 will take priority over the non-emergency and emergency tones.

Speaker Circuits Tab (Bottom Half of DAL Mapping Screen)

- **SPEAKER CIRCUIT** - Select the speaker circuit to be labeled and grouped.
- **CUSTOM LABEL** – Enter up to 20 characters to identify this speaker circuit. By default, this prefills with speaker address reference (e.g. DAA01SPK1).
- **EXTENDED LABEL** – Enter up to an additional 12 characters for more specific identification of the speaker circuit.
- **GROUP NUMBER** – Select the group number for this speaker circuit. Groups consist of a collection of speaker circuits on a DAA2 with one or more amplifiers assigned to it. Refer to Appendix D, “Audio Groups”, on page 86 for more information.

3.6.4 DS-DB Programming Options

Highlight a DAL address configured as a DS-DB to program the device and its associated amplifiers and speaker points.

DS-DB PCA

- **General Settings** - Speaker Riser Mode, Power Supply Installed, Install FTM Module, FFT Riser Wire Selection
- **Low Level Outputs** - Check to install for Connection 1 and for Connection 2: Low-Level Output 1 - 4, High-level Input Primary, Mode, DSBus, Group.
- **Speaker Circuit Settings** - Check to install Speaker Circuit 1 - 8, Group, Wiring Configuration
- **Groups** - Check to install Group 1 - 4; Group Label and Extended Label prefill with speaker-group address reference (e.g. DSDB01GRP1)

3.6.5 DS-DB Field Definitions

DS-DB General Settings Tab

- SPEAKER RISER MODE** – Select desired riser mode from the pull-down menu. A DS-DB can have only one riser mode type; the riser mode type chosen will be applied to all speaker circuits on the DS-DB. Backups must be programmed with the same riser mode type as the primaries. Selecting a Riser Mode setting other than **NORMAL** limits each DS-DB group to one speaker circuit.
 - NORMAL** - Select **NORMAL** when the DAL device will not be used for riser or room isolator applications.
 - RISER TO ADDITIONAL CONTROL MODULES** - Select when the DAL device’s output will be routed to multiple speaker circuits using control modules. In this mode, the DAL device will provide speaker circuit supervision only when idle. Only one DAL device speaker circuit per group may be installed when operating in this mode. Do not use background music on the DAL device in this mode. Refer to the DS-DB manual.
 - RSM OR AIM SERIES ROOM ISOLATORS** - Select when connecting these modules to the DAL device’s speaker circuits. Only one DAL device speaker circuit per group may be installed when operating in this mode. Refer to the appropriate DAL device documentation for more information.
 - CIM OR CSM SERIES ROOM ISOLATORS** - Select when connecting these modules to the DAL device’s speaker circuits. Only one DAL device speaker circuit per group may be installed when operating in this mode. Do not use background music on the DAL device in this mode. Refer to the DS-DB manual.
- POWER SUPPLY INSTALLED** - Check this box if an AMPS-24 power supply is connected to the DS-BUS of this DS-DB.
- INSTALL FTM MODULES** - Check this box if there are FTMs installed on the FFT riser with its Firefighter’s Telephones. When this box is not checked, the address NxxxAyyT - where N = node number, yy = the DAL device address (1 - 32) - can be used for FFT for mapping.
- FFT RISER WIRE SELECTION** - Select **INSTALLED** or **UNINSTALLED** to indicate if there is a riser or not.

DS-DB Low-Level Output Tab

The DS-DB provides up to four low-level outputs (LLO). Each DS-DB low level output can accommodate connection to two devices.

“Connection 1 Settings” allows primary or backup amplifier designation and appears in a column with a green header. “Connection 2 Settings” allows backup amplifier designation only and appears in a column with a blue header (see Figure 3.8).

For each LLO to be programmed at a selected DAL address, enter the following information:

■ Connection 1 Settings

- DEVICE** - Select a device to map it to the low-level DS-DB output. Selection must reflect physical configuration.
- HIGH LEVEL INPUT PRIMARY** - Select the number (1, 2, 3 or 4) of the DS-DB high-level input to be mapped to this device. Selection must reflect physical configuration.
- MODE** - Select the amplifier’s function: Primary or Backup.
- DS-BUS** - Select a DS-BUS address for this amplifier. The DS-BUS accommodates four amplifier addresses. For the DS-BDA, enter the DS-BUS address of the DS-AMP to which it is attached.
- GROUP** - If this amplifier will be part of an audio group, select the group number here. Refer to Appendix D, “Audio Groups”, on page 86, for an explanation of audio groups.

■ Connection 2 Settings

- DEVICE** - Select the device that will act as a backup to map it as a second connection to the low-level DS-DB output. Selection must reflect physical configuration.
- MODE** - Connection 2 Mode must be Backup.
- HIGH LEVEL INPUT BACKUP** - This field displays the high-level input to which this backup amplifier is being mapped.
- DS-BUS** - Select the DS-BUS address at which the backup resides. For the DS-BDA, enter the DS-BUS address of the DS-AMP to which it is attached.

DAL Address		Device Type	Backup Address	BDA Card Mode	DAL Mode
13		DS-DB PCA	No Backup	Not Installed	Primary

LLO	Connection 1 Settings					Connection 2 Settings				
	Low-Level Output	Devices	High Level Input Primary	Mode	DSBus	Group	Devices	Mode	High Level Input Backup	DSBus
1	Not Installed			Primary	0	0	Not Installed	Backup	0	0
2	Not Installed			Primary	0	0	Not Installed	Backup	0	0
3	Not Installed			Primary	0	0	Not Installed	Backup	0	0
4	Not Installed			Primary	0	0	Not Installed	Backup	0	0

Figure 3.8 DS-DB Programming – Low-Level Output Tab

DS-DB Speaker Circuit Settings Tab

- **SPEAKER CIRCUIT** - Check to install each DS-DB speaker circuit (1 through 8). The default is 8 speaker circuits. Click to uncheck the number of any speaker circuit that is not physically installed on the DS-DB.
- **GROUP** - If this speaker circuit will be part of an audio group, select the group number here. Refer to the Appendix D, “Audio Groups”, on page 86 for an explanation of audio groups.

DS-DB Groups Tab

A Group consists of a collection of speaker circuits on a DS-DB with one or more amplifiers assigned to it. Refer to Appendix D, “Audio Groups”, on page 86 for more information.

- **GROUPS** - Check to install each group to be labeled.
- **GROUP LABEL** - Enter up to 20 characters to identify each speaker circuit.
- **EXTENDED LABEL** - Enter up to an additional 12 characters for more specific identification of the speaker circuit.

3.6.6 DVC-RPU Programming Options

RPU-PCC

- **General Settings** - Paging Level 1 - 3, Quick Paging, Page Inhibit, Page Inhibit Logic Equation, KD Inhibit, KD Inhibit Logic Equation, RPU Label.
- **RPU KD** - RPU Keypad Interface Function, Mapping.

3.6.7 DVC-RPU Field Definitions

Use the General Settings Tab to enter information about general behavior of the DVC-RPU in a system. Use the RPU-KD tab to define functions of specific keys on the RPU Keypad.

General Settings Tab

- **PAGING LEVEL 1** - Check this box to enable ALL CALL paging from the top button in column two of the DVC-KD. This button is set to the fixed input number 3. (Refer to “DVC Inputs Branch” on page 59.) Paging Level 1 has the highest priority of the paging levels.
- **PAGING LEVEL 2** - Check this box to enable ALL CALL paging from the second button down in column two of the DVC-KD. This button is set to the fixed input number 5. (Refer to “DVC Inputs Branch” on page 59.) Paging Level 2 has a priority less than Paging Level 1, and greater than Paging Level 3.
- **PAGING LEVEL 3** - Check this box to enable ALL CALL paging from the third button down in column two of the DVC-KD. This button is set to the fixed input number 13. (Refer to “DVC Inputs Branch” on page 59.) Paging Level 3 has a lesser priority than Paging Levels 1 and 2.



NOTE: One, two, or all three Paging Levels may be checked. In Fire only applications, the levels are the DVC-RPU inputs in Table 3.3. In applications with mass notification, the levels are the LOC and general inputs in Table 3.4. See the Mass Notification System manual, P/N LS10063-000NF-E, for more information.

- **QUICK PAGING** - When Quick Paging is enabled, a DVC-RPU button push is not required for paging. Pressing the push-to-talk button on the microphone is sufficient to initiate an ALL CALL page at the Paging Level programmed (1, 2, or 3).
- **PAGE INHIBIT/PAGE INHIBIT LOGIC EQUATION** - Check this box to shut down paging when a logic equation goes active. Enter the logic equation that will activate this function.
- **KD INHIBIT/KD INHIBIT LOGIC EQUATION** - Check this box to lock out all DVC-KD columns when a logic equation is active. Enter the logic equation that will activate this function.
- **RPU LABEL** - Type a label of up to 20 characters; this will identify the individual DVC-RPU at the selected DAL Address.

RPU-KD Tab

There are 24 user-defined keys on a DVC-KD. Refer to Figure 4.1 on page 70 for the numbering format.

- **FUNCTION** - For each of the 24 user-defined keys on the RPU Keypad Interface, select a Function from the drop-down list: Control, Monitor, Disable.
 - **Monitor** - The key will monitor a point for activity.
 - **Control** - The key will activate paging or control points.
 - **Disable** - The key will disable a single local or network DAL device speaker circuit point, or all the speaker circuits on a DAL device.
 - **None** - Default. The key is not programmed.
- **MAPPING** - Enter an address to be controlled, monitored, or disabled as set in the Function field. This must be the address of a specific module, detector, panel circuit point, zone, DAL speaker circuit, or PAM point. VeriFire Tools will validate the mapping’s syntax and source type on entry. Once a Function type is selected, the right side of the screen will display a summary of correct syntax (relevant rules for mapping an appropriate device). The settings will be shared with all the DVC-RPUs connected to the DAL network at the network node address. The syntax for each type of entry is in Table 3.1 below; this is also available on the right side of the VeriFire Tools screen as shown in Figure 3.9.
 - **Monitor function** - Map one source address. Must be a detector, module, panel or bell circuit point, zone, logic zone, trouble zone, releasing zone, special zone, PAM point or speaker point.
 - **Control function** - Map up to 8 points. Source must be a module, panel or bell circuit point, PAM point or general zone.

- **Disable function** -
 - map to one local speaker circuit point.
 - map to one network speaker circuit point.
 - map to disable all speaker circuits on a local DAL device.
 - map to disable all speaker circuits on a network DAL device.

Type of Entry	Syntax*	Explanation
detector	LxxDyyy	xx = panel loop number, yyy = detector SLC address
module	LxxMyyy	xx = panel loop number, yyy = module SLC address
panel circuit	Px.y	x = panel circuit address, y = panel circuit point address
bell circuit	Bx	x = bell circuit address
zone	Zx	x = zone number
logic zone	ZLx	x = logic zone number
trouble zone	ZTx	x = trouble zone number
releasing zone	ZRx	x = releasing zone number
special zone	ZFx	x = special zone number
PAM point	IxxxxAyySz	x = input number, y = DAL device address, z = speaker circuit address
speaker point	AxxSy	xx = DAL device address, y = speaker circuit address
Node	Nxxx	xxx = Noti•Fire•Net. node address
(disable) all speaker points	AAxxD	xx = address of DAL device where all speakers will be disabled

*NOTE: Add Nxxx, where xxx = network node number, at the beginning of the syntax entry if the entry is for a point on a different network node.

Table 3.2 Point Mapping Syntax

Note: If the DVC’s keyboard has been previously programmed and should be duplicated at the DVC-RPU, click the button **CLONE FROM DVC** to copy all keypad mappings.

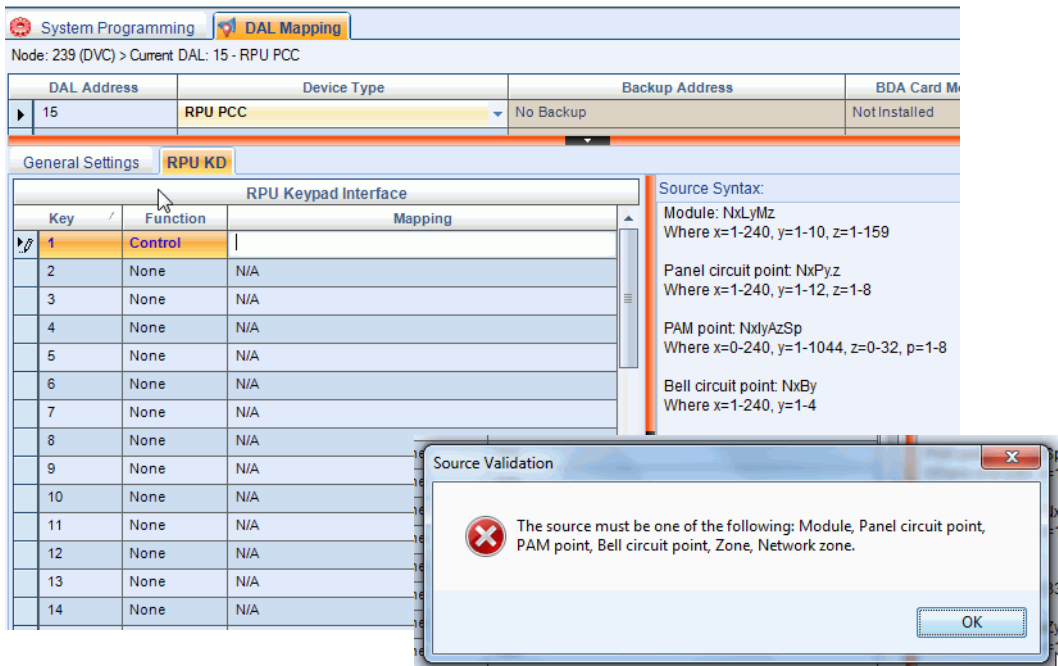

Figure 3.9 DAL Mapping - RPU-KD Keypad Assignment
 (Sample Shows Syntax & Validation Message for Function Type “Control”)

3.7 Audio Message Programming Overview

Up to 1000 message sequences may be created using a sound library available for download with VeriFire Tools and/or separate sound files created through the recommended Goldwave Digital Audio Editor.

These message sequences are assigned DVC Input numbers for use in PAM Programming and Logic Equations. For the equipment requirements for creating a sound library, see the VeriFire Tools Installation Document (PN 51690).



NOTE: The DVC Audio Files are available for download in .zip format from esd.notifier.com. Select standard- or high-quality to match the Fidelity settings for your DVC installation.

Sound files used as message segments must be accessible when downloading to a DVC.

- They must be consistently mapped - that is, the path must remain unchanged if a database is exported onto another PC.
- When accessed from external devices such as a CD drive, copy audio files onto your PC's hard drive, or always ensure that external media containing these files is in the drive when downloading to the DVC.

The preferred digital audio editor must be entered into Preferences on the View menu of VeriFire Tools before it can be used: open the preferences window, click **BROWSE**, and navigate to the editor.

1. Open the Audio Settings Branch (see page 57).
 - Create message segments from .WAV files.
 - Create message sequences by combining commands and message segments/
2. Open the DVC Inputs Branch (see page 59).
 - Set priorities of message sequences on the DVC Inputs branch.
 - Messages 1-1000 appear as Inputs 31-1030 on the DVC Inputs branch.
3. Open the PAM Settings Branch (see page 62).
 - Select and program PAM points for activation; save project.
 - If any points reference a Logic Equation, see Step 4.
4. Open the Logic Equations Branch (see page 66).
 - Create Logic Equations by typing directly or by using the Logic Equation Builder.
 - Create any Logic Equations that will be referenced by a PAM Point; save project.
 - If a Logic Equation references an unavailable PAM Point, return to Step 3.
5. Repeat Step 3 and Step 4 as necessary.
6. If the DVC is configured as a Mass Notification System, see the Mass Notification System manual, P/N LS10063-000NF-E, for instructions on Active Tone Programming.

3.8 Audio Settings Branch

3.8.1 Message Segments

Message segments are sound files that can be used as part of a message sequence. To select and catalog sound files, click on the Audio Settings Branch, and use the Message Segment tab (see Figure 3.10).

Up to 1000 message segments can be stored in the segment library. The actual number may be smaller depending on their size, fidelity, and the DVC board used (DVC or DVC-EM/F/SF).

Fidelity is recorded as “audio type”, which is configured in DVC General Settings. See “Fidelity Selection” on page 44 of Section 3.3.2, “General Settings Branch, Program Settings Tab” for definition of standard- and high-quality .wav files. This setting, and the available message time are displayed as a reminder at the top left of the Message Segments screen. Total time of selected sound files is displayed at the top right of the screen.

Segment Time - Displays length of a specific message segment, in minutes/seconds/decimals (mm:ss:tt).

Segment File - To create a segment file, highlight a Segment Number. Click the **BROWSE** button, navigate to the location where .wav files are stored, and select one to install it.

Message Segment Commands

- **EDIT AUDIO** - Click to open the audio editor configured in VeriFire Tools Preferences. Preferences. (Goldwave Digital Audio Editor or equivalent is recommended.) Create and/or edit sound files with this software program.
- **CLEAR AUDIO** - Click to delete the highlighted Segment Number. This also deletes any message sequences that use the highlighted Segment Number.
- **PLAY AUDIO** - Click to select a .wav file; start and stop playback by using the audio playback buttons in the bottom left of the screen.

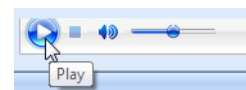

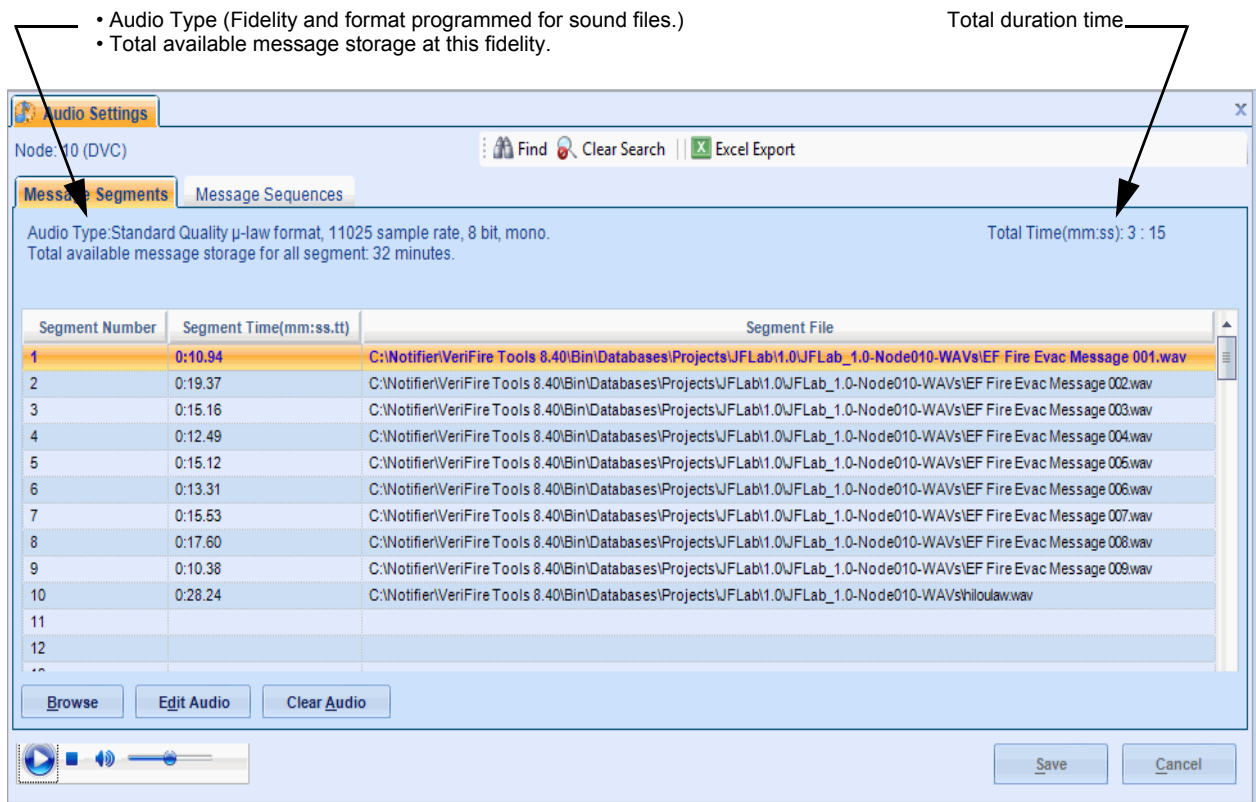

Figure 3.10 Audio Message Programming Service – Message Segments

3.8.2 Message Sequences

Build audio message sequences by combining message segments and sequence commands. A sequence may have up to 125 steps.

Create an audio sequence:

1. Select a Sequence Number on the MESSAGE SEQUENCES data-entry grid. Assign the sequence an ALERT, EVAC, or OTHER message type.



NOTE: Only Alert and Evac may be used when a DVC with DVC-AO is directly connected to an NFS2-640 panel.

2. Optional: Type a Sequence Label (up to 20 characters) to identify the audio sequence.
3. Click the plus icon to expand a Message Sequence Number to view the sequence-step set-up grid.
4. Use the drop-down selections to Assign Sequence Commands (Command File, Wave File, None).
 - For steps configured as “Command File”, select Sequence Value as Play Forever, End Play, or Play [#] Times (up to 14 times). VeriFire Tools will check these values against existing system configurations and prompt for a change if the selection is inappropriate.
 - For steps configured as “Wave File, select from a drop-down list of installed message segments.
5. Segments may be grouped together and the group or individual segment may be played up to 14 times. An individual segment or group may also be commanded to play forever.



NOTE: For public mode signaling, messages activated during fire events must repeat indefinitely (the PLAY FOREVER command must be used). For private mode signaling, fire alarm messages may be of finite length (the PLAY X TIMES command may be used), but they must then be assigned the “OTHER” category. Security, supervisory, trouble, all finite-length messages, and all messages not activated by fire events must be assigned “OTHER” in VeriFire Tools.

Each PLAY... command (PLAY X TIMES, PLAY FOREVER) must be completed with an END PLAY command. Segments without a PLAY.../END PLAY command will play only once. Note that the PLAY... and END PLAY commands are comparable to open (PLAY X TIMES, PLAY FOREVER) and closed (END PLAY) brackets of a logic equation.

Sequences may be nested, as shown in Figure 3.11.

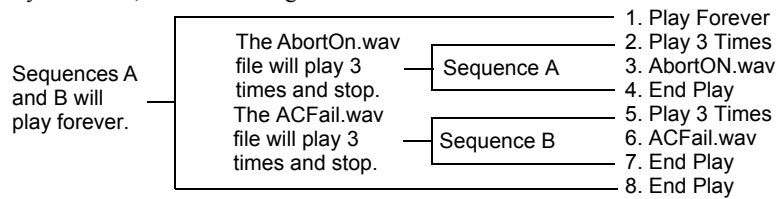

Figure 3.11 Nested Sequence

■ Sample Message Sequence

One typical message sequence is shown in Figure 3.12:

Step 1. Sequence Command is a Command File set to “Play Forever”.

Step 2. Sequence Command is a Wave File selected from those configured in Message Segments.

Step 3. Sequence Command is a Command File set to “End Play”.

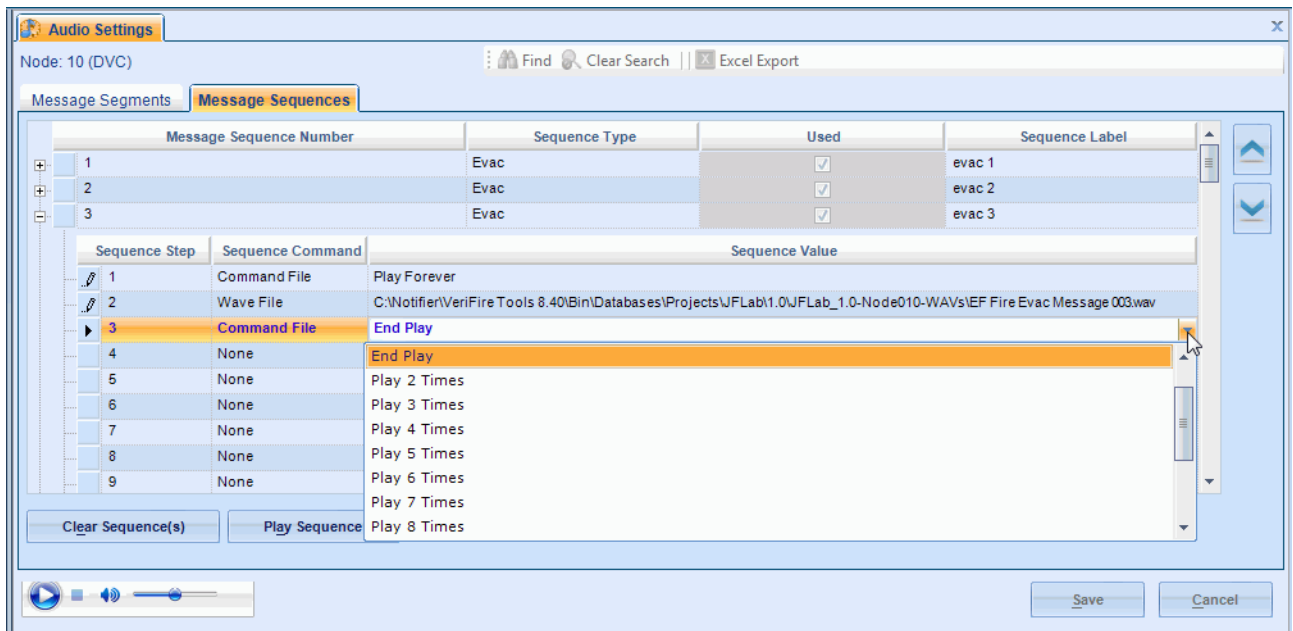

Figure 3.12 Audio Message Programming Service – Message Sequences

Message Sequence Commands

- **CLEAR SEQUENCE** - Click this button to delete all steps in a sequence. If VeriFire Tools displays a checkmark in the “Used” column, the deletion will affect at least one Logic Equation or PAM Point. VeriFire Tools will prompt before deleting, but it is advisable to review where a sequence is used before deleting it.
- **PLAY SEQUENCE** - Click this button to select and listen to the sequence as a test; start and stop playback by using the audio playback buttons in the bottom left of the screen. . During this test, the **PLAY FOREVER** command will only play 200 times. When this sequence is activated in a non-test situation, **PLAY FOREVER** will play indefinitely.



3.9 DVC Inputs Branch

The DVC Inputs branch displays all inputs available for the currently configured system so the relative priority of events can be easily viewed and edited.

Each input source, live or recorded, is assigned a fixed input number and a programmable priority number. Use the Inputs service to program each input’s priority. The lower the priority number, the higher the priority. Fixed Input Numbers are used to program logic equations, and they create the input row address in PAM processing.

Note that Inputs 31–1030 only display if an Audio Message Sequence has been created for that row (See “Audio Message Programming Overview” on page 57.)

Fire System vs Mass Notification System: The fixed inputs for the first fourteen rows of a system have a different setting depending on whether the DVC is configured as a Fire System or as a Mass Notification System. Table 3.3 on page 61 describes all the input rows for a DVC system that is configured as a standard fire system. Table 3.4 describes the first fourteen input rows that are different for UL 2572 mass notification applications. See the Mass Notification System manual, P/N LS10063-000NF-E, for more information.

Click on a header to sort by the contents of that column.

To reassign input priority:
Type a new number in the priority field
OR
Highlight a row and click Up/Down.

Rows between Input 31 and Input 1030 only display if an Audio Message Sequence has been created for that row. See See "Audio Message Programming Overview" on page 57.

Input	Priority	Source	Category
14	14	RPU Network Paging Level 3	General
16	31	Local Tel	General
17	32	Network Tel	General
31	33	evac 1 (Sequence 1)	General
32	34	evac 2 (Sequence 2)	General
33	35	evac 3 (Sequence 3)	General
34	36	evac 4 (Sequence 4)	General
35	37	evac 5 (Sequence 5)	General
36	38	evac 6 (Sequence 6)	General
37	39	evac 7 (Sequence 7)	General
38	40	evac 8 (Sequence 8)	General
39	1035	evac 9 (Sequence 9)	General
40	1037	hilo (Sequence 10)	General
1035	1	Workstation Emergency	General
1037	2	Workstation Non-Emergency	General
1038	1038	Local RM-1	General
1039	1039	Network RM-1	General

Figure 3.13 DVC Inputs

UP/DOWN - Highlight an input and click "Up" or "Down" to change its order in the priority sequence. It is also possible to type a new number to reassign the priority of an individual input. For example, in Figure 3.13 on page 60, to move "evac 1 (Sequence 1)" ahead of "Network Test", highlight Input 31 and click "Up". Another way too get the same result, is to retype the priority for Input 31 as "32".



CAUTION: FFT-NFN PRIORITY CAUTION

1. DO NOT PROGRAM FFT-NFN WITH A PRIORITY GREATER THAN ANY INPUT USED FOR EMERGENCY PAGING OVER NFN OR IT WILL BE PRE-EMPTED WHEN FFT-NFN IS IN USE. THE DVC ENDPOINTS OF AN FFT-NFN LINK MUST BE PROGRAMMED WITH THE SAME FFT-NFN PRIORITY.

RENUMBER - Click the button to sequentially reassign priorities to all inputs.

RESTORE DEFAULTS - Click this button to re-apply default priorities to all inputs. See Table 3.3 on page 61 for defaults.



NOTE: Local DVC-RPU input priority values must maintain the following relationship:
Local RPU Level 1 < Local RPU Level 2 < Local RPU Level 3

Input Number	Input Source	Default Priority
1	Local Microphone Page	1
2	Network Microphone Page	2
3	DVC-RPU Local Page Level 1	3
4	DVC-RPU Network Level 1	4
5 - 9	RESERVED	—
9	DVC-RPU Level 2	9
10	Network DVC-RPU Level 2	10
11 - 12	RESERVED	11
13	DVC-RPU Level 3	13
14	Network DVC-RPU Level 3	14
15	RESERVED	15
16	Local Telephone Page	16
17	Network Telephone Page	17
18 – 30	RESERVED	—
31	Message Sequence 1	31
32	Message Sequence 2	32
...
1029	Message Sequence 999	1029
1030	Message Sequence 1000	1030
1031 – 1033	RESERVED	—
1034	RESERVED	—
1035	Network Workstation	1035
1036	RESERVED	—
1037	Network Remote Workstation	1037
1038	Local RM-1	1038
1039	Network RM-1	1039
1040	Local AUXB	1040
1041	Network AUXB	1041
1042	FFT-NFN	1042
1043	Local AUXA	1043
1044	Network AUXA	1044

Table 3.3 Default Input Priorities
(DVC Configured for Fire System, Not for Mass Notification)



NOTE: Keying the local microphone will switch the paging source to the local microphone regardless of priorities when paging functions are active from a source other than the local microphone. Paging functions are ALL CALL, PAGE ACTIVE EVAC AREAS, PAGE ACTIVE ALERT AREAS, and PAGE INACTIVE AREAS.

Input Number	Input Source	Default Priority	Category
1	ACU Local Paging Level 1	1	Level 1 Fire, MN or General
2	ACU Network Paging Level 1	2	
3	LOC Local Paging Level 1	3	
4	LOC Network Paging Level 1	4	
5	CCS Local Paging Level 1	5	
6	CCS Network Paging Level 1	6	
7	ACU Local Paging Level 2	7	Level 2 Fire, MN or General
8	ACU Network Paging Level 2	8	
9	LOC Local Paging Level 2	9	
10	LOC Network Paging Level 2	10	
11	CCS Local Paging Level 2	11	
12	CCS Network Paging Level 2	12	
13	Local General Paging	13	General
14	Network General Paging	14	

Table 3.4 First 14 Default Input Priorities (DVC Configured for Mass Notification)

3.10 PAM Settings Branch

Open the PAM Settings branch for Prioritized Audio Matrix (PAM) Programming. This data-entry grid allows editing of all programmed inputs and outputs.

- Inputs are represented by rows.
- Outputs are represented by columns.
- A PAM point is the intersection between an input and an output.

The PAM Settings branch in VeriFire Tools provides a blue column of information about a particular input, followed by columns for all outputs on the network.

Input priority is assigned when the DVC Inputs are configured; see Section 3.9, “DVC Inputs Branch”. Backup digital amplifiers (DAA/DAA2/DAX) are not valid outputs; their programming will match that of their primary device.

Outputs are arranged in order of node and speaker number; columns are color-coded by DAL device.

When a cell is highlighted for editing, the current PAM point address will display at the top of the PAM Settings data-entry grid.

3.10.1 Prioritized Audio Matrix (PAM) Programming Overview

Addressing a PAM Point

A PAM point address describes its input (I) number, amplifier (A) number, and speaker circuit (S) number (IxxxxAxxSx). Local DVC analog outputs use amplifier number zero. Where live paging over a standard or high-speed Noti•Fire•Net is employed, Noti•Fire•Net is considered an output on the source DVC. The points associated with the intersection of the live inputs with Noti•Fire•Net have a PAM point address of IxxxxNET, where “I” is the input number.

Activating a PAM Point

Following are the means to activate a PAM point:

- Logic Equation.
- ACS control (ACS mapping on NFS2-3030, or NCA-2).
- Point control (“Force On”/“Force Off” commands - network workstation, NCA-2, or NFS2-3030).
- DVC-KD (Pre-set paging buttons (ALL CALL, etc) and user-programmed buttons).

The PAM Programming screen shown in Figure 3.14 allows the programmer to select and program points for activation using a specific logic equation. ACS control, point control and DVC-KD activators do not display on this screen. To display and edit the full configuration for one speaker, select its cell; the full configuration for the selected speaker displays in the bottom half of the screen.

The programmer may also program the point for signal silence participation and switch inhibit, as described in Table 3.9 on page 65. As information is entered for a particular input, it drops to the bottom of the list until the grid is next sorted.

PAM View - Click the PAM View button to filter the data-entry grid to display and edit all of one type of information for all installed speakers. Available types are Logic equation, Silenceable, Switch inhibit, CBE-1 - CBE-4, and All CBEs. When “Logic equation” is selected, for example, all programmed logic equations are available at the drop-down list. “Silenceable” starts with the default settings for all speakers. “Switch Inhibit” defaults to uninstalled.

PAM Legend - Click the “PAM Legend” button in the lower right corner to display a list of keyboard shortcuts. VeriFire Tools uses standard Windows shortcuts such as moving from cell to cell with arrow keys. Additional keyboard shortcuts are provided to make it possible to navigate the PAM Settings branch without a mouse.

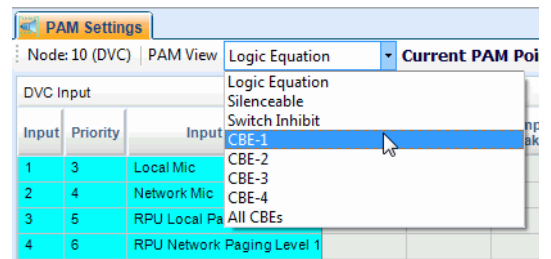

NOTE:

- Logic Equations must be programmed and the VeriFire Tools project must be saved before those Logic Equations are available for PAM Point Programming.
- Logic equations may not be mapped to DVC-RPU rows.

Outputs are represented by columns. *Example:* Output circuit Column for DAA2, Address 10, Speaker Circuit 1 in Group 1. The selected cell in the column is a PAM point in the row designated Input 38, and has a PAM point address of I38A10S1. When Logic Equation 8 (the “8” that is being selected in the drop-down list) is activated, Input 38 will broadcast Sequence 8 on this output. This output can also be activated by other PAM points in its column.

PAM View allows quick filtering to outputs of particular types; this example shows Logic Equations.

Address for the selected PAM point

Inputs are represented by rows. *Example:* Input 38 Row. The selected cell in the row is a PAM point. When Logic Equation 8 is activated, Speaker Circuit 1 on Group 1 of DAA2 Address 10 will broadcast evac sequence 8

Programming options for PAM point activation. See “Programming a PAM point” on page 65.

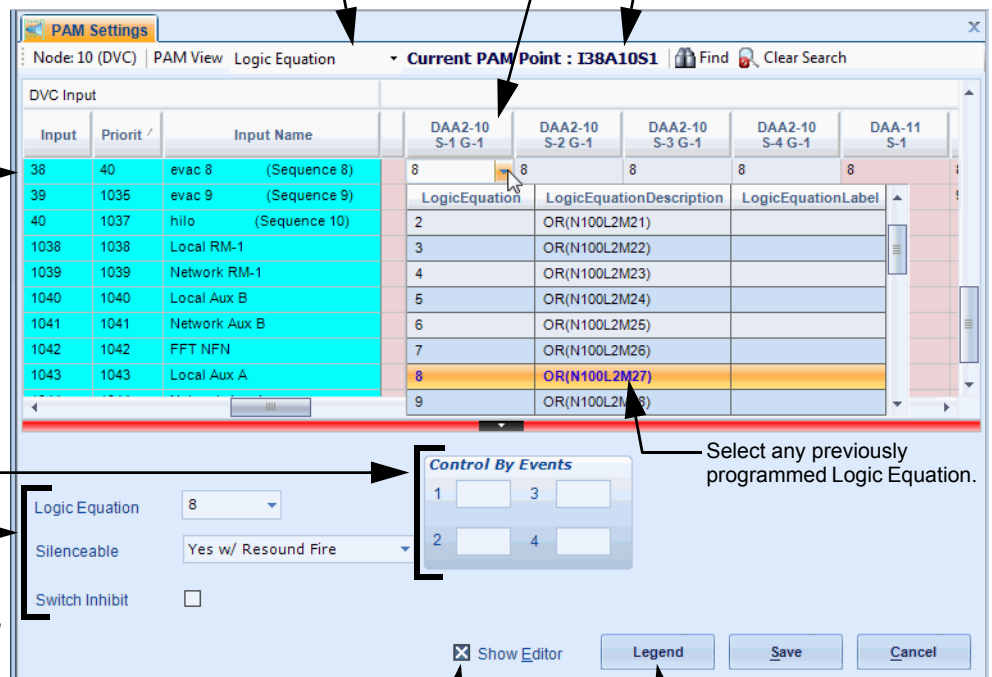

Select any previously programmed Logic Equation.

Click to hide the bottom half of the screen.

Click to display PAM keyboard shortcuts

Figure 3.14 PAM Programming Screen

3.10.2 Network Paging

When “NFN Audio Paging” is selected in the DVC General Settings (see page 45), the DVC is configured to send live audio to a standard or high-speed Noti•Fire•Net for audible output by other DVCs on the network.

The live audio present on the network can be used as input audio by another DVC on Noti•Fire•Net, and may be played on any output circuit on that DVC.

Inputs designated as “Local” in the PAM of the source DVC become “Network” inputs of the same type in the PAM of all other network DVCs. (See Table 3.5.)

Input Name on Source DVC	Input Name on Other Network DVC
Local Mic	Network Mic
Local Tel	Network Tel
Local RM-1	Network RM-1
Local Aux B	Network Aux B
Local Aux A	Network Aux A

Table 3.5 Local and Network Inputs

A DVC configured for network audio output may be commanded to transmit a live audio message to Noti•Fire•Net in a variety of ways. An MIC-1 Local Mic will always (provided the audio channel is free, or the input has sufficient priority to pre-empt another audio source using the channel) transmit its audio to Noti•Fire•Net when the Push-to-talk button on the microphone is depressed.

Live inputs from other than the MIC-1 may be activated to transmit to Noti•Fire•Net using “Enable Paging from *input name*” buttons programmed to an annunciator button on an NCA-2, NFS2-3030 or DVC-KD. A pre-defined button labeled “Enable Telephone Page” exists on the DVC-KD for this purpose.

Live inputs may also be activated to Noti•Fire•Net using a logic equation. This programming is done in the PAM Programming Service, by mapping the logic equation to the NET column of the desired local input. The NET column appears only when “Paging to Network” is selected in the DVC Programming Service.

■ Network Paging From this DVC, RM-1 Example

The RM-1 at this DVC is configured with an NCA-2 or NFS2-3030 annunciator (one button with a mode of ENABLE PAGING FROM RM-1, one button with a mode of ALL CALL) and programmed to transmit an ALL CALL message to other nodes.

When the RM-1 is activated for network paging (by first pressing the two annunciator buttons, then the microphone’s push-to-talk button), it will send a live ALL CALL message out to Noti•Fire•Net through the PAM’s Local RM-1 input (Input 1038).

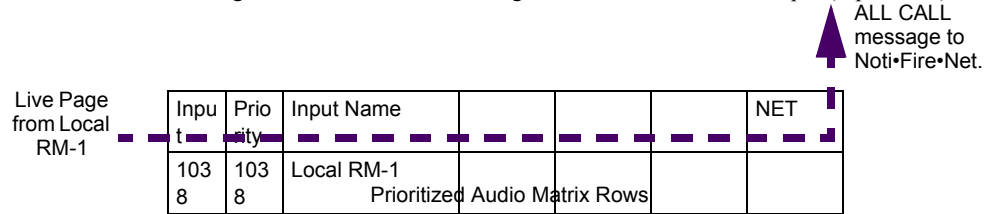

Figure 3.15 Network Paging from This DVC

■ Network Paging to this DVC, RM-1 Example

An RM-1 at another node initiates a live ALL CALL page over a standard or high-speed Noti•Fire•Net to this DVC.

The message will be sent to the target output(s) through the PAM’s Network RM-1 Input (1039) to ALL CALL outputs at this DVC node

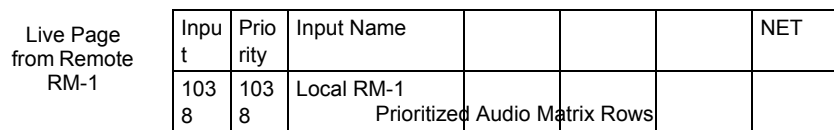

Figure 3.15 Network Paging to This DVC

3.10.3 Message Overrides

When a PAM point is activated, its input will broadcast on its output. If more than one PAM point activates for a particular output, the PAM point with the highest priority input will play first, and it will pre-empt active messages of lesser priority. The pre-empted message will be set to either pending or turned off, as shown in Table 3.8 below.

	Live		Evac		Alert		Other	
	PAM point turned on by logic equation	PAM point turned on by user (annunciator button or Alter Status)	PAM point turned on by logic equation	Turned on by user (annunciator button or Alter Status)	PAM point turned on by logic equation	Turned on by user (annunciator button or Alter Status)	PAM point turned on by logic equation	Turned on by user (annunciator button or Alter Status)
Live	Pending	OFF	Pending	OFF	Pending	OFF	Pending	OFF
Evac	Pending	OFF	Pending	OFF	OFF	OFF	OFF	OFF
Alert	Pending	OFF	Pending	OFF	Pending	OFF	OFF	OFF
Other	Pending	OFF	Pending	OFF	Pending	OFF	Pending	OFF

Table 3.8 Operation of Message Overrides

Live - an input that was not created by Audio Sequence programming (that is, paging, telephone communication).

Evac, Alert, Other - Message type assigned to an audio sequence through Audio Sequence programming.

Pending - means the new input will pre-empt the active input, but will allow that input to resume its broadcasting once the new input has completed its broadcast.

OFF - means the new input will pre-empt the active input, and will turn it off.

■ Message Override Example

A live page with a priority of one (1) occurs while an “Evac” message, initiated by a logic equation, is broadcasting. The live input has a higher priority than the “Evac” message. Table 3.8 shows that the new live message will cause the “Evac” message to be placed in a pending state. (The table cell where the “Live” row intersects with the “Evac, PAM point turned on by logic equation” column says “Pending”.) The “Evac” message will resume once the live page is completed.

3.10.4 Programming a PAM point

Select a cell at the intersection of an input and an output. The point address will display at the lower right corner of the service. Choose how the PAM point will activate, and whether signal silence participation and switch inhibit will be enabled.

LOGIC EQUATION – Enter a logic equation to have the PAM point activate when the conditions set in the logic equation are met. Choose from the logic equations displayed in the “Available Logic Equations” part of the screen. The Logic Equation Builder on page 66 describes how to set up these logic equations.

SILENCEABLE – This field determines whether the user can manually silence a PAM point. Based on the value chosen from the list below, a Signal Silence command at a network annunciator, or at a single-panel NFS2-640 or NFS2-3030 directly connected to a DVC, will silence a PAM point, as described in Table 3.9.

Pull-down Menu Selections	Description	Resound
NO	Not manually silenceable	N/A
YES w/RESOUND FIRE	Silenceable, resound on fire alarm events	Network and Local Resound
YES w/RESOUND SUPERV	Silenceable, resound on supervisory events	Network and Local Resound
YES w/RESOUND SECURITY	Silenceable, resound on security event	Network and Local Resound
YES w/RESOUND TROUBLE	Silenceable, resound on local DVC trouble event	Network and Local Resound
YES w/o RESOUND	Silenceable	No Resound

Table 3.9 Silenceable Settings



NOTE: Recorded messages programmed to activate based on security events must be programmed as non-silenceable; NO must be selected.

SWITCH INHIBIT – When this selection is enabled, the PAM point will disregard any ACS control.

CONTROL-BY-EVENT - Type in up to four DVC General Zones to map these zones to the PAM point being programmed. When that PAM point activates, it will in turn activate any of its mapped general zones. (For a related topic, see “DVC General Zones” on page 50.)

3.11 Logic Equations Branch

VeriFire Tools allows the programmer to set up Control-by-Event requirements for audio events in two different ways. Users can type established Logic Equations directly into the data-entry grid. (Note that this includes copying equations from other Windows programs and pasting them into the cells in this data-entry grid.) Users also can use the Logic Equation Builder. This provides a graphic point-and-click method to build the equation by choosing from lists of available operators and operands as the equation is built at the top of the screen.

Both methods do basic error-checking before writing equations to the database; users are prompted with the source of error. The Program Validation Service should also be run after equations are complete.

Select the Logic Equations branch on the Edit Session Tree. The screen's left side provides the equation data-entry grid, containing completed equations. The right side provides the DVC Logic Equation Builder. At the bottom of the screen are three overall function buttons: View All System Trouble Descriptions, Save, and Cancel.

3.11.1 Logic Equation Data-Entry Grid

The Logic Equation data-entry grid allows you to select, view, or navigate through up to 2000 (ZL1 – ZL2000) logic equations. This data-entry grid can be sorted, filtered, and exported to Excel.

LOGIC EQUATION - Type an equation directly into this field, paste text in from another source, or highlight this row to activate the Logic Equation Builder on the right side of the screen.

LABEL - Use this field to enter a label (up to 100 characters) for the logic equation. Labels are accessible by viewing the database using VeriFire Tools.

3.11.2 Logic Equation Builder

The top of the Logic Equation Builder screen displays the ID number of the logic equation number being worked on, with the current equation being programmed. A Comments field is provided for identifying notes that do not affect DVC programming. The rest of the screen is divided into three sections:

- Edit and Save Changes.
- Functions.
- Points.

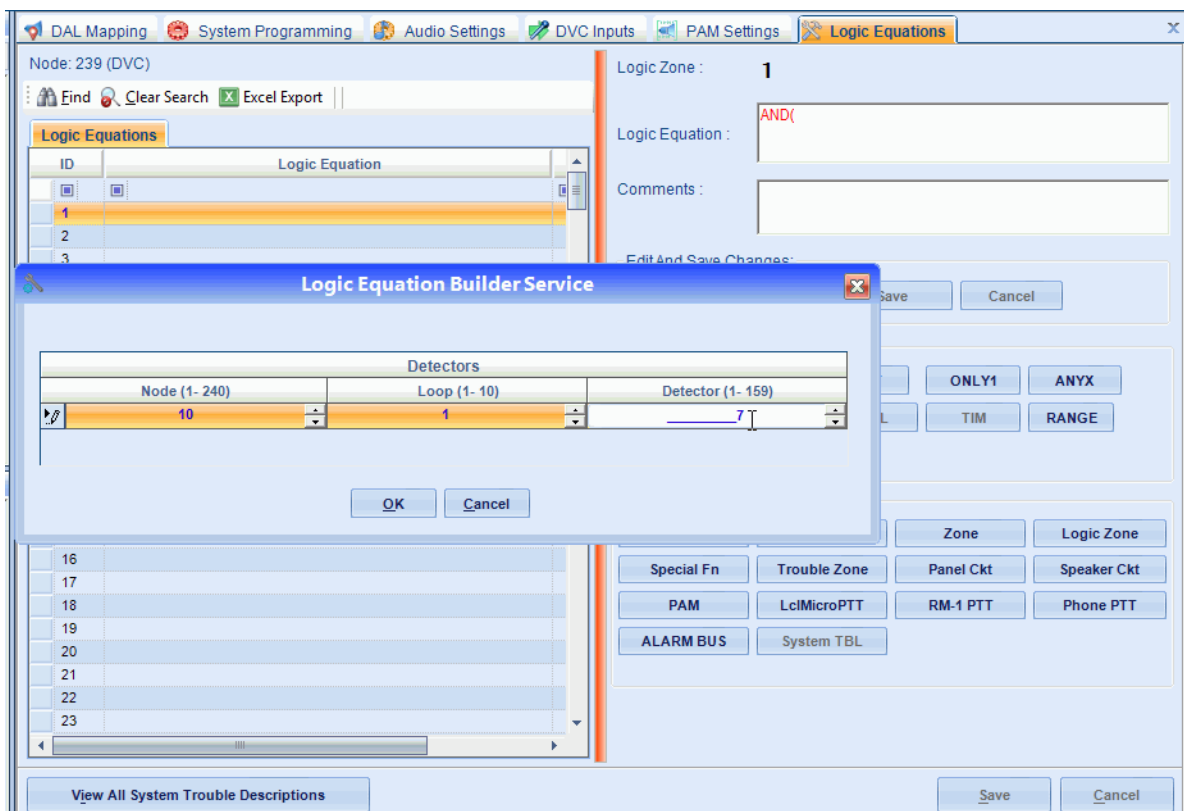

Figure 3.15 Logic Equation Builder Service

3.11.3 Edit and Save Changes (Logic Equation Commands)

- **UNDO** - This button will undo the last function that was executed. You can press the **UNDO** button until the entire entered equation is erased.
- **REDO** - This button will reverse the action of the **UNDO** button. The **REDO** button can be pressed until the entire function is recovered.
- **SAVE** - This button saves the current equation to the database, and writes it to the list on the left side of the screen.
- **CANCEL** - This button will erase the current equation so that a new equation can be entered. Once the **CANCEL** button is pressed, both the **UNDO** and **REDO** button will become unavailable.

3.11.4 Functions (Logic Equation Operators)

The Functions section lists the available operators to use. For every step that can be performed, the available choices will be left enabled, while unavailable options will be grayed out. Following is a description of each function. Refer to the VeriFire Tools help file for more information.

- **AND** - Requires that each argument be active.
- **OR** - Requires that any argument be active.
- **NOT** - Inverts the state of the argument (activated to deactivated OR deactivated to activated).
- **ONLY1** - Requires that only one argument be active.
- **ANYX** - Requires that the amount of arguments specified by the number preceding the arguments be active.
- **TBL** - Requires the system trouble(s) listed to activate.
- **DEL** - Used for delayed operations.
- **SDEL** - A latched version of the DEL function. Once the equation evaluates true, it remains activated until a reset, even if the internal equation becomes false.
- **TIM** - The TIM function specifies activation on specific days of the week or year.
- **RANGE** - Each argument within the range must conform to the requirements of the governing function. The range limit is 20 consecutive arguments.
- **)** - Closes a logic equation.

3.11.5 Points (Logic Equation Operands)

The Points section allows the user to select operands that can be added to an equation. Pressing one of these buttons will bring up a dialog box to help you enter the appropriate address for the device or zone being used in the equation. The address formats shown in Table 3.10 are enforced by VeriFire Tools.



NOTE: A PAM Point must be programmed and the VeriFire Tools project must be saved before that PAM Point is available for reference by Logic Equations.

Point	Format	Description
Detector	NxxLyyDzzz	xxx = node #, yy = loop #, zzz = detector address
Module	NxxLyyMzzz	xxx = node #, yy = loop #, zzz = module address
Panel Circuit	NxxPy.z	xxx = node #, yy = panel circuit #, z = panel circuit point
Zone	NxxZyyy	xxx = node #, yyy = zone #
Logic Zone	NxxZLyyyy	xxx = node #, yyyy = logic zone #
Trouble Zone	NxxZTyyy	xxx = node #, yyy = trouble zone #
Special Function	NxxZFyy	xxx = node #, yy = special function zone #
System Trouble	NxxTyyy	xxx = node #, yyy = system trouble
Speaker Circuit (DAL Device)	NxxAyySz	xxx = node #, yy = 1-32 (DAL device address), z = speaker circuit
PAM	NnnlxxxAyySz	nnn = node #, xxxx = Input #, yy = 0-32 (0 = DVC, 1-32 = DAL device address)
PAM (net)	NnnlxxxNET	nnn = node #, xxxx = input #
Local Microphone PTT (over Noti•Fire•Net network)	NxxMIC	xxx = node #
Local Microphone PTT (local DVC)	MIC	n/a
RM-1 PTT (over Noti•Fire•Net network)	NxxAyyRM	xxx = node #, yy = 0-32 (0 = DVC, 1-32 = DAA2 address)
RM-1 PTT (local DVC DAL)	AxxRM	xx = 0-32 (0 = DVC, 1-32 = DAL device address)
Local Phone PTT (over Noti•Fire•Net network)	NxxAyyTELE	xxx = node #, yy = 0-32 (0 = DVC, 1-32 = DAL device address)

Table 3.10 Point Address Format

Point	Format	Description
Local Phone PTT (local DVC DAL)	AxxTELE	xx = 0-32 (0 = DVC, 1-32 = DAL device address)
Alarm Bus (over Noti•Fire•Net network)	NxxxAyyBUS	xxx = node #, yy = 0-32 (0 = DVC, 1-32 = DAL device address)
Alarm Bus (local DVC DAL)	AxxBUS	xx = 0-32 (0 = DVC, 1-32 = DAL device address)

Table 3.10 Point Address Format

3.11.6 DAL Device Alarm Bus Activation Using Logic Equation Programming

DVC software 4.0 and higher provides the ability to program DAL device speaker circuits to activate based on the following two conditions:

1. Loss of communication with the local FACP.
2. Active input on the DAL device’s local alarm bus.

A DVC can now be programmed to activate the DAL device and play a specific message for these conditions. A logic equation must be created that includes the two conditions.

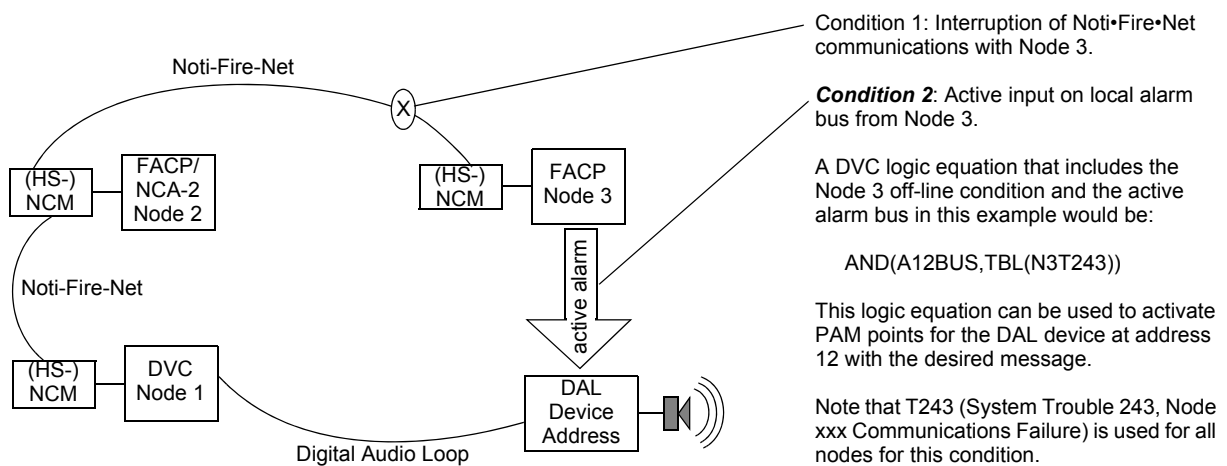

Figure 3.16 Alarm Bus Activation Conditions with Programming Example

3.12 Special Function Zones

The DVC has four special function zones resident within it that may be used to activate outputs in logic equations, and may be directly monitored by KD points. These are hard-coded into the device, and not changeable by VeriFire Tools; they may only be referenced by VeriFire Tools programming.

ZF1 - This special function zone will go active whenever a DVC system trouble is active. It can be used in a DVC logic equation to activate outputs on the DVC. A logic equation with ZF1 in it may also be used to combine the activation of any system trouble with another condition.

Examples:

- To activate an output when any system trouble is active on the DVC, program the logic equation “OR(ZF1)” into the input’s PAM row.
- To activate an output when any system trouble is active on the DVC and there is also an active monitor module, program “AND(ZF1,NxxxMyyy) - where xxx = node number, yyy = module number - into the output’s PAM row.

System trouble index numbers are listed in Table C.1 on page 81. They may be used in logic equations without Special Function Zone ZF1 to activate an output when a specific DVC system trouble goes active.

ZF16 - This special function zone will go active whenever a network drill (alarm signal for Canadian applications) is initiated. It can be used in logic equations to activate outputs on the DVC in the event of a network drill/alarm signal.

Example:

- To use ZF16 at the DVC to activate a PAM point when a network drill/alarm signal is initiated at any node, program the logic equation “OR(ZF16)” into the input’s PAM row.
NOTE: To use a specific node’s ZF16 to activate a PAM point when that node initiates a network drill/alarm signal, program the logic equation “OR(NxxxZF16)” into the input’s PAM row.
A “MAN EVAC RECEIVED” trouble will be generated whenever ZF16 is active.

ZF20 - This special function zone will go active whenever an MN (mass notification) alarm is activated. An active ZF20 suppresses fire activations in MN-mapped nodes in networks where MN is the highest priority. ZF20 may be used in logic equations to activate outputs when an MN alarm occurs. It is required in the logic equation for the MN Active Tone. (See the Mass Notification System manual, P/N LS10063-000NF-E, for more information.)

ZF21 - This special function zone will go active whenever an MN (mass notification) supervisory is activated. It can be used in logic equations to activate outputs on the DVC when an MN supervisory message activates. (See the Mass Notification System manual, P/N LS10063-000NF-E, for more information.)

3.13 Program Validation

The message sequences created through audio message programming are prioritized in this part of VeriFire Tools programming.

Use Program Validation before you attempt to download a new database. In VeriFire Tools 8.00 and higher, select the Utilities tab, and click the Program Validation tab. This can also be done from Edit Session tree; right-click on a node and select Validate. This function will check the validity of the program that was created for a DVC. VeriFire Tools checks the following items:

- Check message segments. Any message segments that are not in the correct format will be flagged.
- Check message sequences. Any message segments in the sequences that are not programmed will be flagged. Any message segments which are programmed, but the wave file does not exist, will also be flagged. Any message sequences that are not syntactically correct will also be flagged.
- Check logic equations. If a logic equation specifies a logic zone that does not have a logic equation, an error is flagged. When a logic equation is entered, forward reference checking is performed so that a logic equation cannot contain a logic zone that is the same or greater than the logic zone being programmed.
- Check PAM points. Any referenced logic zones that are not programmed will be flagged. In addition, these unreferenced logic zones will also be removed from the database. Any PAM points that reference the alarm bus will be flagged if the alarm bus does not have any nodes mapped.
- Check logic zone references. Any logic zones that have a logic equation specified must appear in another logic equation or in the PAM. If it does not appear in any of these locations, an error is flagged with a note that the logic zone may be used in another node's zone map or logic equation.
- Check local emergency and non-emergency message segments. If the message segment is not programmed, it will be flagged. If the message segment is programmed, but the .wav file does not exist, it will also be flagged. If the duration of the messages exceed 106 seconds, an error will flag it.
- Check pre-announce messages. If the message sequence is empty, it will be flagged.
- Check group settings. Each group needs at least one amplifier and at least one speaker circuit assigned to it.

If the Program Validator detects errors in the database, a warning message will appear and the Program Validation Results screen will display all detected errors. Clicking on each parameter listed under the Cause or Effect column will bring up the appropriate programming screen for editing.

VALIDATE - Click this button to validate the database.

EXPORT TO PDF/EXPORT TO EXCEL - Click this button to save the validation results to a file for storage or printing.

CAUSE/EFFECT - Click in a cell to jump to the location where invalid programming can be fixed.

3.14 Reports

VeriFire Tools generate printed reports and electronic exports. The selections can be viewed, sorted, and printed from the drop-down Reports Menu. Select the "Reports" or the "Compare Nodes" icon. Each report option is clearly named to indicate the type of included information:

- General Settings.
- All Call & Special Function Map.
- DAA/DAA2/DAX Mappings.
- DS-DB Mappings.
- DVC-RPU.
- KD Mapping.
- General Zones.
- Audio Messages.
- Audio Sequences.
- DVC Inputs.
- PAM Settings.
- Logic Equations.
- Complete Panel Report.
- **Compare Nodes**. This separate report icon allows the user to select two DVC nodes with the same database version; nodes can be in the same or different projects. Specify type of data to compare; differences will be highlighted.

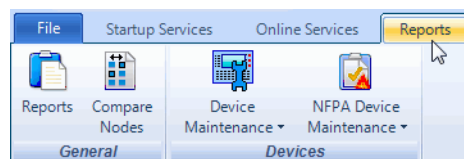

Section 4: DVC Operation

4.1 Using the DVC-KD Keypad on the DVC

When a DVC is used with a DVC-KD keypad, it operates with a network annunciator or NFS2-3030 as an audio command center, accepting and routing live paging, with LED status indicators for paging and other functions.

The DVC-KD contains push-button switches and indicators of two types:

- Those with pre-set functionality, all located along the two left columns.
- Twenty-four user-programmable buttons similar to those on the ACM-24AT annunciators, all located along the two right columns.

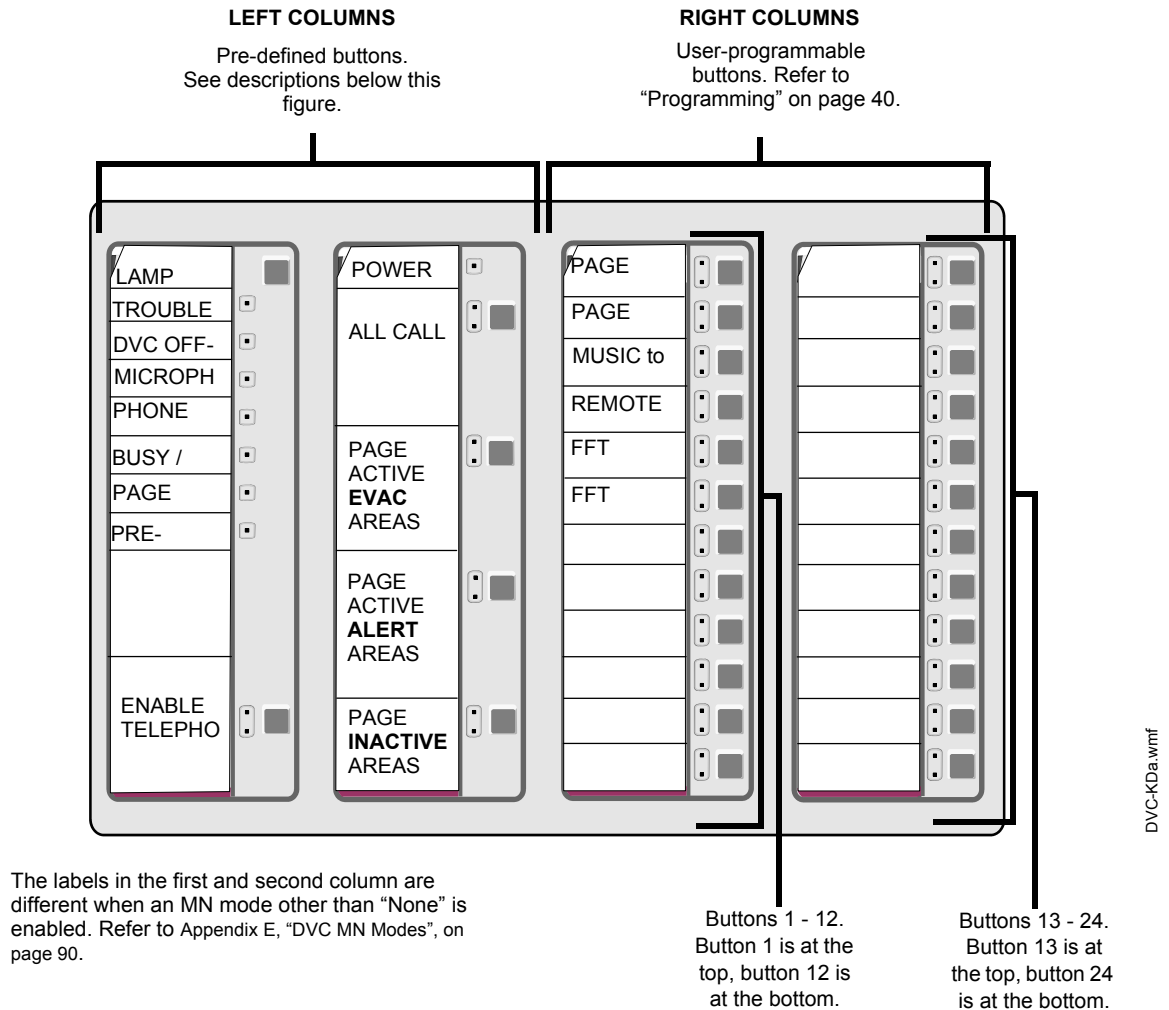

Figure 4.1 DVC-KD Keypad

4.1.1 Pre-defined Buttons/Indicators

Buttons When MN Mode = None

Figure 4.1 illustrates the label configuration in the two left columns when MN Mode = None.

LAMP TEST

Press and hold to perform a lamp test of all the LEDs on the keypad. LEDs on the DVC will also be tested with the following exceptions: Reset, TXA, TXB, RXA and RXB.

ENABLE TELEPHONE PAGE

Press this button to engage/disengage ALL CALL, PAGE ACTIVE EVAC AREAS, PAGE ACTIVE ALERT AREAS and PAGE INACTIVE AREAS paging from the DVC's TELH-1 telephone handset or an FFT on a DVC or DAL device riser.



NOTE: The ALL CALL, PAGE ACTIVE EVAC AREAS, PAGE ACTIVE ALERT AREAS, and PAGE INACTIVE AREAS buttons will function only when "Local Control" has been selected in VeriFire Tools programming.



NOTE: A local microphone page, initiated at the DVC's MIC-1, will pre-empt a local telephone page from the DVC's TELH-1 or an FFT on the DVC or a DAL device riser.

ALL CALL

Press this button to initiate ALL CALL paging. DVC nodes that will receive the ALL CALL message are determined by VeriFire Tools programming. The green "active" LED will light if any of the mapped nodes are online. When one or more nodes are off-line, the yellow "trouble" LED will blink. If both the green and yellow LEDs are lit, paging can still proceed, broadcasting to all mapped nodes that are online.

PAGE ACTIVE EVAC AREAS

Press this button to initiate paging to active evacuation areas. This feature is only available for standard fidelity DVCs (multi-channel). Nodes that will receive the PAGE ACTIVE EVAC AREAS message are determined by VeriFire Tools programming. The green "active" LED will light if any of the mapped nodes are online. When one or more nodes are off-line, the yellow "trouble" LED will blink. If both the green and yellow LEDs are lit, paging can still proceed, broadcasting to all mapped nodes that are online.

PAGE ACTIVE ALERT AREAS

Press this button to initiate paging to active alert areas. This feature is only available for standard fidelity DVCs (multi-channel). Nodes that will receive the PAGE ACTIVE ALERT AREAS message are determined by VeriFire Tools programming. The green "active" LED will light if any of the mapped nodes are online. When one or more nodes are off-line, the yellow "trouble" LED will blink. If both the green and yellow LEDs are lit, paging can still proceed, broadcasting to all mapped nodes that are online.

PAGE INACTIVE AREAS

Press this button to initiate paging to inactive areas. This feature is only available for standard fidelity DVCs (multi-channel). Nodes that will receive the PAGE INACTIVE AREAS message are determined by VeriFire Tools programming. The green "active" LED will light if any of the mapped nodes are online. When one or more nodes are off-line, the yellow "trouble" LED will blink. If both the green and yellow LEDs are lit, paging can still proceed, broadcasting to all mapped nodes that are online. Paging to inactive areas will only work when the bandwidth is available, and will not take priority over messages currently playing. For example if the system is using all eight channels to play different EVAC messages to different outputs, it is not going to pre-empt the lowest priority EVAC to page to the inactive areas.

Buttons When MN Mode = ACU, LOC, or CCS

Figure E.1 on page 90 illustrates the label configuration in the two left columns when MN Mode = ACU, LOC or CCS.

LAMP TEST

Press and hold to perform a lamp test of all the LEDs on the keypad. LEDs on the DVC will also be tested with the following exceptions: Reset, TXA, TXB, RXA and RXB.

Level 1 (User Labeled)

Press the highest button in column 2 to create an ALL CALL page at the highest priority.

- If the Level 1 input category is MN, pressing this button will create an MN page locally and to all MN mapped nodes, initiating an MN alarm.
- If the Level 1 input category is Fire, pressing this button will create an ALL CALL fire page locally and to all mapped nodes.

Level 2 (User Labeled)

Press the second button down in column 2 to create an ALL CALL page at level 2 priority.

- If the Level 2 input category is MN, pressing this button will create an MN page locally and to all MN mapped nodes, initiating an MN alarm.
- If the Level 2 input category is Fire, pressing this button will create an ALL CALL fire page locally and to all mapped nodes.

Level 3 (User Labeled)

Press the 3rd button down in column 2 to create an ALL CALL general page at level 3 priority locally and to all mapped nodes.

4.1.2 LED Indicators

- **Trouble** - Illuminates steady during system initialization and when there are acknowledged troubles at the DVC node. Blinks for unacknowledged troubles.
- **DVC Offline** - Illuminates when the DVC is not providing fire protection. For example, there is a problem with the DVC that requires service.
- **Microphone Trouble** - Illuminates when a connection failure exists, or when a DVC microphone page has been initiated but no microphone activity has occurred for 17 seconds.
- **Phone Trouble** - Illuminates when a connection failure exists, or when a DVC telephone page has been initiated but no telephone activity has occurred for 17 seconds.
- **Busy/Wait** - Illuminates when a code or database download from the DVC to DAL devices is in effect.
- **Page Inhibited** - Illuminates when a page ends, as the system inhibits another page from being initiated for 3 seconds. It will also illuminate when another node has assumed paging control and locked out paging from this DVC. This occurs when the DVC requests paging permission over a standard or high-speed Noti•Fire•Net from the DCC node (refer to "Display and Control Center (DCC)" on page 73), and the DCC has not granted it. Also illuminates when the Page Inhibit feature is active.
- **Pre-Announce** - Illuminates while the pre-announce sequence is playing before paging from the DVC's MIC-1 local microphone.

4.1.3 24 User-programmable Buttons

These buttons are programmed in VeriFire Tools to perform annunciator-type control, monitor and telephone functions within the system.

4.2 Paging

The MIC-1 microphone, TELH-1 telephone handset, RM-1 remote microphone, and AUXA and AUXB inputs can perform paging operations to their local DVC or across a standard or high-speed Noti•Fire•Net to another DVC.

FFTs on the DVC/DAL device FFT risers can perform paging operations to the DVC node or the network.

4.2.1 MIC-1 Microphone Paging

To page using the MIC-1:

1. Remove the microphone from its cradle.
2. Press the DVC-KD button for the desired paging zone (for this example, ALL CALL). The green LED at the ALL CALL button will light steady.
3. Press the push-to-talk button on the microphone. If there is a pre-announce tone, it will play at this time and the Pre-Announce LED will light as it plays. Wait until this LED goes off before paging.
4. Page.
5. Release the push-to-talk button on the microphone.
6. Press the ALL CALL button to disengage the ALL CALL function. The green LED will turn off.



NOTE: The DVC-KD Microphone Trouble LED will illuminate briefly if paging is initiated but there is no activity for 17 seconds. After the 17 seconds have elapsed, the LED will light, MIC-1 microphone paging will terminate, and the LED will go out.

4.2.2 TELH-1 Telephone Paging

To page using the TELH-1:

1. Remove the handset from its cradle.
2. Press the ENABLE TELEPHONE PAGE button. The green LED at the button will light steady.
3. Press the DVC-KD or annunciator button for the desired paging zone (for this example, ALL CALL). The green LED at the ALL CALL button will light steady.
4. If there is a pre-announce tone, it will play at this time and the Pre-Announce LED will light as it plays. Wait until it ends before paging.
5. Press the handset's push-to-talk button.
6. Page.
7. Release the push-to-talk button on the TELH-1.
8. Press the ENABLE TELEPHONE PAGE button to disengage the ALL CALL function. The green LEDs at the ALL CALL and ENABLE TELEPHONE PAGE buttons will turn off.



NOTE: The DVC-KD Telephone Trouble LED will illuminate briefly if paging is initiated but there is no activity for 17 seconds. After the 17 seconds have elapsed, the LED will light, TELH-1 telephone paging will terminate, and the LED will go out.

4.2.3 RM-1 Remote Microphone Paging



NOTE: RM-1 usage is not supported for Canadian DCC Applications.

To page using a DVC's RM-1:

Configured with Annunciator

1. Remove the microphone from its cradle.
2. Press the annunciator button(s) mapped to the RM-1.
 - Specific Local Paging (when there is no ENABLE PAGING button) - Press the single button for the specific area to be paged (i.e. Cafeteria) to enable paging. The annunciator LED will blink.
 - Specific Network Paging - Press the ENABLE PAGING button, then press the button for the specific area to be paged (i.e. Cafeteria, East Wing). The annunciator LEDs will blink.
 - General Local and General Network Paging - Press the ENABLE PAGING button, then press the button for the type of paging desired (ALL CALL, PAGE EVAC, PAGE ALERT, PAGE INACTIVE). The annunciator LED(s) will blink.
3. If there is a pre-announce tone, it will play at this time and the Pre-Announce LED will light as it plays. Wait until it ends before paging.
4. Press the push-to-talk button.
5. Page.
6. To end the page, release the push-to-talk button and press the *paging function* button (not the ENABLE PAGING button) to deactivate. The annunciator LED(s) will turn off.

Configured with Keyswitch

1. Remove the microphone from its cradle.
2. Insert and turn the key in the keyswitch. (A monitor module must monitor the keyswitch that will drive logic to turn on the necessary PAM points)
3. If there is a pre-announce tone, it will play at this time and the Pre-Announce LED will light as it plays. Wait until it ends before paging.
4. Press the push-to-talk button.
5. Page.
6. To end the page, release the push-to-talk button and turn the key back to its original position.

4.2.4 AUXA/AUXB Paging

To page using a DVC's AUXA or AUXB inputs:

1. Activate the AUXA or AUXB input.
2. Press the annunciator button(s) mapped to it.
 - Specific Local Paging (when there is no ENABLE PAGING button) - Press the single button for the specific area to be paged (i.e. Cafeteria) to enable paging. The annunciator LED(s) will blink.
 - Specific Network Paging - Press the ENABLE PAGING button, then press the button for the specific area to be paged (i.e. Cafeteria, East Wing). The annunciator LEDs will blink.
 - General Local and General Network Paging - Press the ENABLE PAGING button, then press the button for the type of paging desired (ALL CALL, PAGE EVAC, PAGE ALERT, PAGE INACTIVE). The annunciator LED(s) will blink.
3. Press the push-to-talk button.
4. Page.
5. To end the page, release the push-to-talk button and press the *paging function* button (not the ENABLE PAGING button) to deactivate. The annunciator LED(s) will turn off.

4.2.5 FFT Paging

To page using an FFT handset on the DVC's FFT riser or the FFT riser on one of its DAL devices, refer to Appendix B.1, "FFT Paging", on page 76.

4.3 Display and Control Center (DCC)

A Display and Control Center (DCC) is a display location which can respond to events occurring at other participating locations. While there may be multiple Display and Control Centers on a network, an individual location can only accept the commands of one DCC at a time. The user's actions at any participating station, panel, or remote display determine which location will be the DCC.

VeriFire Tools programming determines whether a DVC has or does not have DCC capabilities. The DVC does not have a display or indicator showing it has DCC control, and so it must be mapped in VeriFire Tools to an NCA-2 or network workstation. When the ALL CALL, PAGE ACTIVE ALERT AREAS, PAGE ACTIVE EVAC AREAS, PAGE INACTIVE AREAS, or ENABLE TELEPHONE PAGE button is pressed at a DCC-designated DVC, the DVC will attempt to get control of the network for its associated NCA-2 or network workstation. The "Controls Active" LED on the panel will light when control has been granted, and paging can proceed. When the NCA-2 gets control, it will be in control of itself, the DVC, and all the nodes in the ALL CALL list.

DCC is not used in a Mass Notification system. Refer to the section titled Mass Notification Control Operation in the Mass Notification manual.

4.4 Trouble Messages

Refer to Appendix C, "Trouble Messages", on page 81 for troubles generated by the Digital Voice Command system.

Non-displayed Events

The DVC will generate messages for activations/deactivations that do not normally display at network annunciators. They can be displayed at a network workstation by viewing the Background Activations screen. Refer to the network workstation manual. The notation will appear as IxxxxAyySz, where xxxx equals the input number, yy equals the DAL device address, and z equals the speaker circuit (1, 2, 3, or 4).

Read Status

The NCA-2, NFS2-3030, a network workstation, as well as a computer running VeriFire Tools and connected to the NUP port of the DVC, will be able to read the status of a DVC. Refer to the appropriate panel manual or VeriFire Tools for Read Status display information.

Appendix A: DAL Earth Fault Detection

Detection of earth faults on the DAL (Digital Audio Loop) falls into two categories, depending on the model.

Category	Models in this Category	Description
Two Earth Fault Switches	DVC-EM (PCA and PCB versions) All DAA wire models	There are two earth fault switches on a wire DVC and DAA - EFA and EFB - one for each isolated digital audio port. These switches can be set to detect earth faults on a specific section of the DAL. The earth fault switch is enabled at the end of the DAL segment that will do the earth fault detection. When an earth fault occurs on that segment, a specific earth fault error is generated for the DAA/DVC that has its switch enabled. All other earth faults are indicated by the power supply powering the DAL device when earth fault detection is enabled.
One or No Earth Fault Switches	DVC-EM (PCC and higher versions) All DAA2 models All DAX models DS-DB DVC-RPU	There are no earth fault switches for specific digital audio ports on a DVC-EMPCC, DAA2, DAX, DS-DB, and DVC-RPU. Enabling the power supply's earth fault switch will initiate detection on the device as well as on the section of DAL being monitored. If there is an earth fault anywhere, a general earth fault error for that device will generate. Only DAP A (Digital Audio Port A) is isolated. Earth fault detection is always off at DAP A. Supervision is performed at the other end of the connection. The DAX-50 does not have general earth fault detection. The device charging the DAX-50's batteries must have earth fault detection enabled, to provide earth fault notification for the DAX-50.

Table A.1 Earth Fault Detection Categories

When devices are sharing batteries, only one device in the sharing set may have its earth fault switch enabled or its JP2 jumper left intact. If an earth fault occurs anywhere on the DAL segments in the set, an earth fault error will generate for the device with its switch enabled or its jumper intact. Refer to the battery sharing sections of each device for more information on wiring this configuration.

Refer to Figure A.1 on page 75 for an illustration.

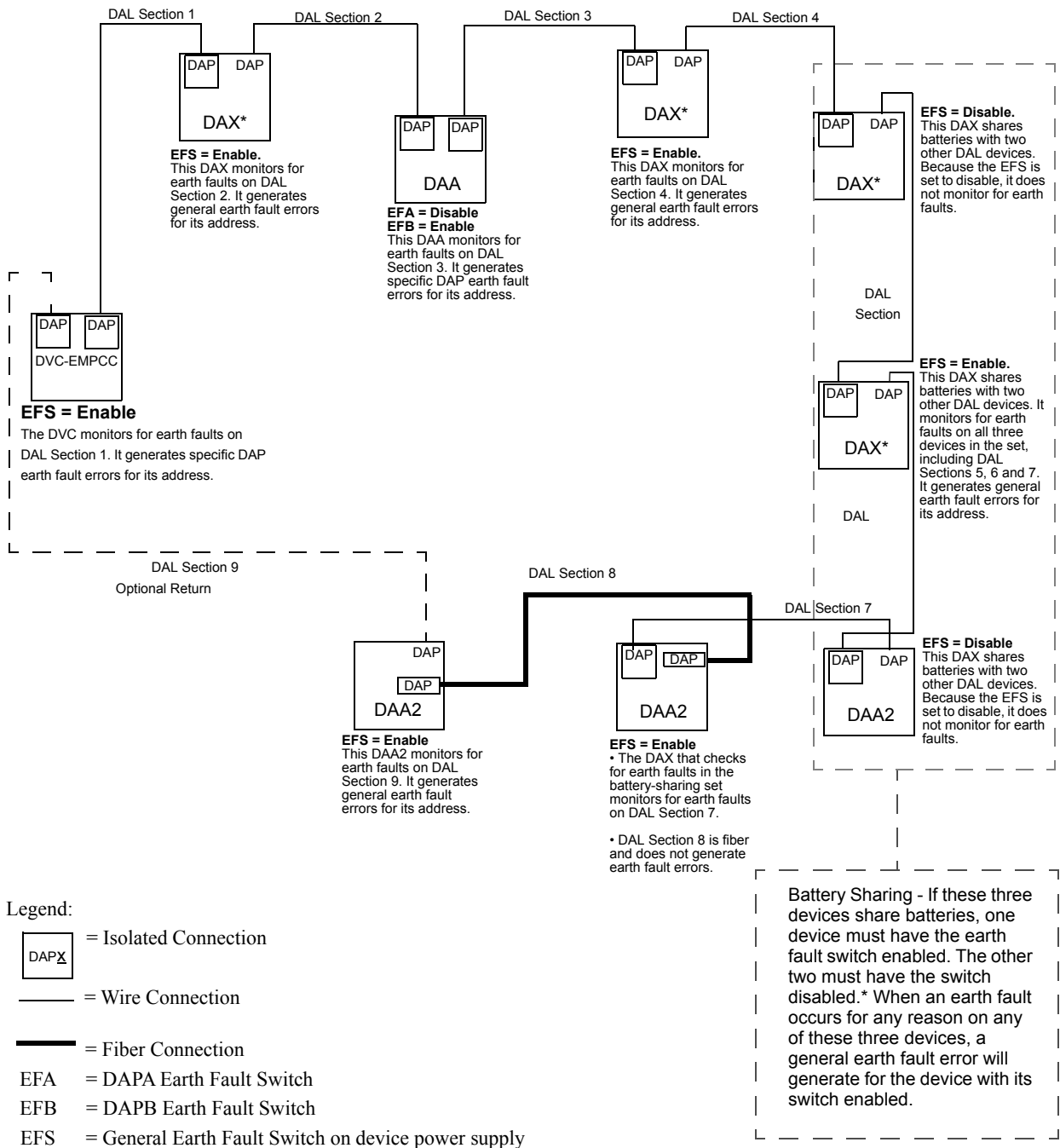

*DAX-50s do not have general earth fault detection. Earth fault detection must be provided by what is charging the DAX-50's batteries.

Figure A.1 DAL Earth Fault Settings Illustration

Appendix B: FFT Communication

B.1 FFT Paging

To page using an FFT handset on the DVC's FFT riser or the FFT riser on one of its DAL (Digital Audio Loop) devices, follow the instructions below.

■ Configured with Annunciator

1. Activate the handset for FFT communication by lifting the receiver or plugging in the phone jack.
2. Press the annunciator button(s) mapped to the FFT.
 - Specific Local Paging (when there is no ENABLE PAGING button) - Press the single button for the specific area to be paged (i.e. Cafeteria) to enable paging. The annunciator LED(s) will blink.
 - Specific Network Paging - Press the ENABLE PAGING button, then press the button for the specific area to be paged (i.e. Cafeteria, East Wing). The annunciator LEDs will blink.
 - General Local and General Network Paging - Press the ENABLE PAGING button, then press the button for the type of paging desired (ALL CALL, PAGE EVAC, PAGE ALERT, PAGE INACTIVE). The annunciator LED(s) will blink.
3. Press the push-to-talk button.
4. Page.
5. To end the page, release the push-to-talk button and press the *paging function* button (not the ENABLE PAGING button) to deactivate. The annunciator LED(s) will turn off.

■ Configured with Keyswitch

1. Activate the handset for FFT communication by lifting the receiver or plugging in the phone jack.
2. Insert and turn the key in the keyswitch. (A monitor module needs to monitor the keyswitch that will drive logic to turn on the necessary PAM points)
3. Press the push-to-talk button.
4. Page.
5. To end the page, release the push-to-talk button and turn the key back to its original position.

■ Not Configured for Paging

1. The DVC operator must press the ENABLE TELEPHONE PAGE button, then the paging function button.
2. Press the push-to-talk button to page.
3. When paging is complete, release the push-to-talk button. The DVC operator must press the ALL CALL button, then the ENABLE TELEPHONE PAGE button to end the page.

B.2 DVC Firefighter's Telephone Network Communication

B.2.1 FFT Communication Local to DVC Node

The DVC Firefighter's Telephone network consists of the DVC's own analog riser and the analog risers that exist on any of the (up to) 32 DAL devices connected to the DVC. (For FFT communication over Noti•Fire•Net, refer to "Point-to-point FFT Communication over Noti•Fire•Net (FFT-NFN)" on page 77).

FFT network activation (that is, when a handset on one of these risers is granted a connection by the operator) allows intercommunication between the DVC's FFT analog riser and up to four other dynamically-changing sets of FFT risers on the DAL devices. Each riser can sustain seven active FFT handsets, so 35 handsets may be active within the network at the same time. If this number is exceeded, a short circuit trouble will be generated by the DVC; however, FFT communications will continue.



NOTE: The FFT riser on the DVC is always one of the five active risers. Four FFT risers can be active on digital audio amplifiers at the same time.



NOTE: An active RM-1 remote microphone on a DAA2 will take up one of the five FFT riser channels, and will take propriety over local FFT communication. Refer to "**RM-1 Settings (DAA2 only)**" on page 53 for more information.



NOTE: The DVC's TELH-1 connection (J8) always counts as one of the seven active FFT handsets on the DVC, whether there is a TELH-1 handset connected to it or not.

Figure B.1 and the text that follows gives an example of how activated analog FFT risers interact with the DAL.

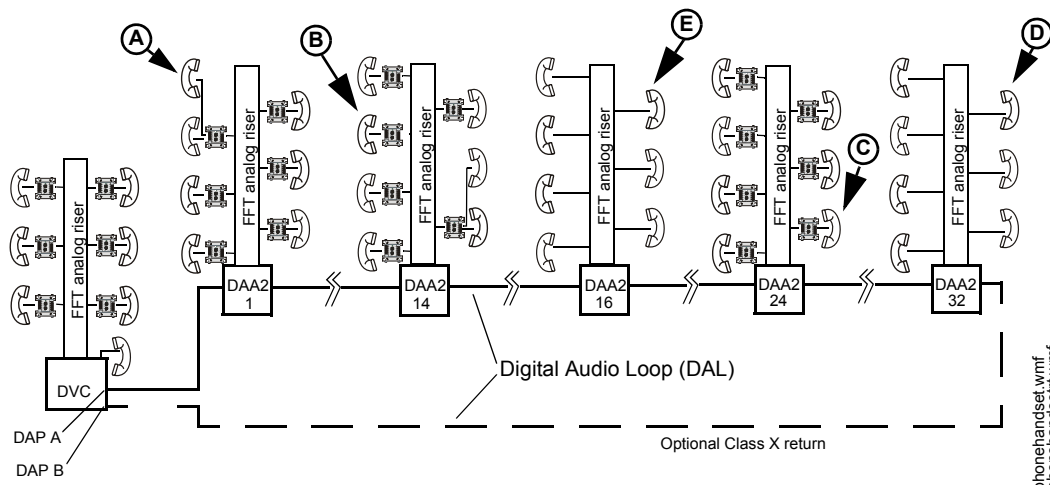

Figure B.1 Active DVC Firefighter's Telephone Network

1. A firefighter at DAA2 1 activates a handset (A) on the analog FFT riser by lifting the receiver or plugging in a phone jack. An operator at the DVC grants the firefighter a connection.
 - (A) will be able to communicate with other phones that activate on the DAA2 1 analog FFT riser.
 - (A) will automatically be granted a Digital Audio Loop (DAL) connection.

1 (DAA2 1) analog riser + 1 (DVC) analog riser = 2 risers interconnected on the DAL.
2. Subsequently, firefighters at DAA2 14 (B), DAA2 24 (C), and DAA2 32 (D) activate handsets and are granted connections by the operator.
 - (B), (C), and (D) will be able to communicate with other phones on their respective FFT analog risers.
 - (B), (C), and (D) will automatically be granted DAL connections.

4 (DAA2 1, 14, 24 and 32) analog risers +1 (DVC) analog riser = 5 risers - the maximum allowed -interconnected on the DAL.
3. A firefighter at DAA2 16 activates a handset (E) and is granted a connection by the operator.
 - (E) will hear a ring tone on his handset.
 - (E) will be placed in a queue for the next available connection, because the maximum of five risers on the DAL has already been reached. (E) will hear the ring tone until either (A), (B), (C), or (D) is disconnected by the operator.

B.2.2 Point-to-point FFT Communication over Noti•Fire•Net (FFT-NFN)

DVC software release 3.2 and higher supports FFT communications between two DVC digital audio loops on the same standard or high-speed Noti•Fire•Net network. All DVC systems must be running DVC software Version 3.2 and NCM software Version 3.40 or higher or any HS-NCM software, as well as NFS2-3030/NCA-2 software Version 14.1 or higher. All DVCs and DAAs must be PCB version hardware (not PCA versions) or higher.

■ Example 1

Refer to Figures B.2 and B.3 for this example.

A call initiated at an FFT (C) on a DVC node can be answered at another DVC (A). This will require turning on two communication links:

1. the link between the FFT (C) and its DVC (B), and
2. the link between DVC (A) and DVC (B) (the FFT-NFN link on a standard or high-speed Noti•Fire•Net).

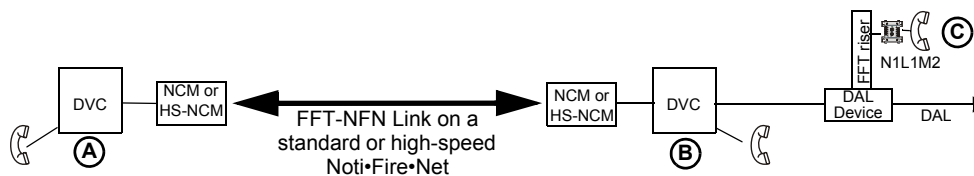

Figure B.2 FFT-NFN Communication Links Example 1

One DVC-KD or ACS annunciator point is required to establish and terminate this communication. The point must be programmed with the ACS function/mode "FFT-NFN". Figure B.3 shows the point programming.

DVC-KD or ACS programming:
 ACS function/mode = **FFT-NFN**
 Mapping: as indicated in point label

Point mapping - connects (A) to (B) to (C)

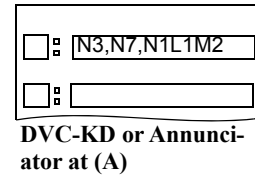

Figure B.3 Point Programming for Figure B.2 Example

This setup would operate as follows:

1. A firefighter jacks in at (C). Point 1 rings at (A). Both LEDs flash.
2. The operator at (A) presses the point button, programmed as shown in Figure B.2, turning on the point. The point active LEDs will light steady on, and the yellow LEDs will go off. Communication is established between (C) and the local telephone at (A).
 - The *N3,N7* portion of the point programming controls the network communication - (A) to (B) in this example.
 - The *N1L1M2* portion of the point programming controls the telephone communication between the field telephone and the DVC at node 3. (In this example, N1 would be the panel controlling the telephone module.)



NOTE: The FFT-NFN link will accommodate communication between two DVCs at a time. If the FFT-NFN link is in use by two other DVCs when the Point 2 button is pressed, the attempt to link (A) and (B) will be denied.

3. When the FFT-NFN connection is no longer needed, the operator at (A) disconnects the call by pressing the point button to disconnect. The FFT-NFN link will be automatically disconnected, because no other points are active at the DVC-KD or annunciator on the (A) to (B) link. The link will close once all the active FFT-NFN points mapped to the DVC-KD or annunciator have been turned off.

Example 2

Refer to Figures B.4 and B.5 for this example.

Calls initiated at more than one FFT on a DVC node can be answered at another DVC. This communication requires turning on the following communication links:

1. the links between the FFTs and their local DVC (B) to (C), (D), and (E), and
2. the link between DVC (A) and DVC (B) (the FFT-NFN link on Noti•Fire•Net).

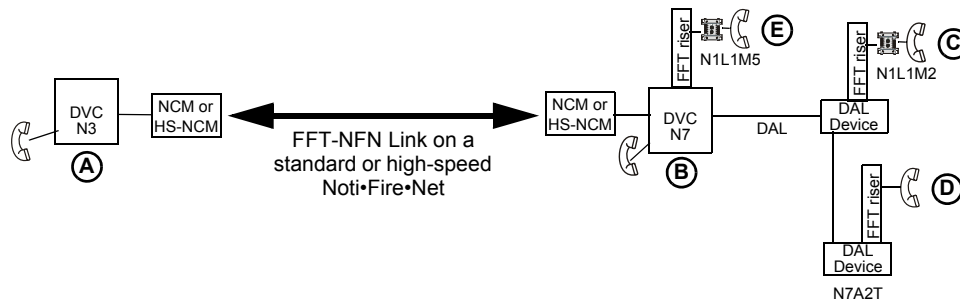

Figure B.4 FFT-NFN Communication Links Example 2

DVC-KD or ACS annunciator points are required to establish and terminate this communication. These points must be programmed with the ACS function/mode "FFT-NFN". Figure B.5 shows the point programming.

DVC-KD or ACS programming:
 ACS function/mode = **FFT-NFN**
 Mapping: as indicated in
 point label

Point 1 mapping - connects (A) to (B) to (C)	Point 1	<input type="checkbox"/> N3,N7,N1L1M2
Point 2 mapping - connects (A) to (B) to (D)	Point 2	<input type="checkbox"/> N3,N7,N7A2T
Point 3 mapping - connects (A) to (B) to (E)	Point 3	<input type="checkbox"/> N3,N7,N1L1M5
		<input type="checkbox"/>

DVC-KD or Annunciator at Node 3

Figure B.5 Point Programming for Figure B.4 Example

This setup would operate as follows:

1. A firefighter jacks in at (C). Point 1 rings at (A). Both LEDs flash (green and yellow at the DVC-KD, point active and yellow at the annunciator).
2. The operator presses Point 1, turning on the point. The point active LEDs will light steady on, and the yellow LEDs will turn off. Communication is established between (C) and the local telephone at (A). If pressing Point 1 activates (C) but does not open the FFT-NFN link, the (A) and (C) point LEDs will continue to flash because the FFT-NFN link is not available.
3. Firefighters jack in at (D) and (E). Points 2 and 3 ring at (A), the point active LEDs light steady and the yellow LEDs flash. The operator at (A) presses the Point 2 and 3 buttons (either the Point 2 and 3 DVC-KD buttons or the Point 2 and 3 ACS annunciator buttons), programmed as shown in Figure B.2, turning on the points. The yellow LEDs will turn off. Communication is established between the field telephones at (C), (D) and (E) and the local telephone at (A). (A) through (E) are now in communication.



NOTE: (D) is on a riser with no telephone control modules installed, so mapping is to the DAL device in the format NxAxT, where A = device address on the DAL (digital audio loop).

4. (C) jacks out. The operator presses Point 1 to terminate the connection with (C). Points (D) and (E) are still active, and continue to communicate over the FFT-NFN link.
5. (D) and (E) jack out. The operator presses Points 2 and 3 to terminate these connections. The FFT-NFN link automatically terminates, because no FFT-NFN programmed points remain active on it.

Example 3

Refer to Figures B.6 and B.7 for this example.

A call initiated at an FFT on a DVC node can be connected to an FFT on another DVC's digital audio riser. This communication requires turning on three communication links:

1. the link between the FFT (F) and its DVC (A).
2. the link between DVC (A) and DVC (B) (the FFT-NFN link on a standard or high-speed Noti•Fire•Net).
3. the link between the FFT (C) and its DVC (B).

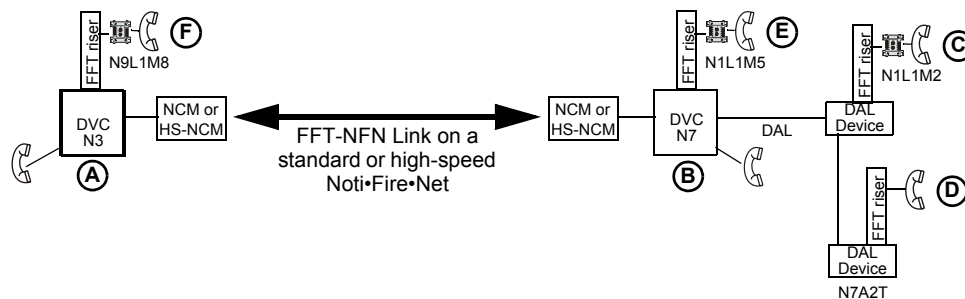
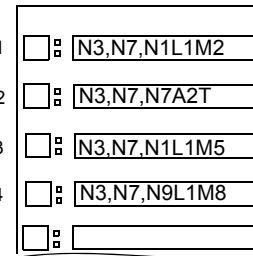

Figure B.6 FFT-NFN Communication Links Example 3

DVC-KD or annunciator points are required to establish and terminate this communication. These points must be programmed with the ACS function/mode "FFT-NFN". Figure B.7 shows the point programming.

DVC-KD or ACS programming:
 ACS function/mode = **FFT-NFN**
 Mapping: as indicated in point label

Point 1 Mapping - Connects (A) to (B) to (C) Point 1
 Point 2 Mapping - Connects (A) to (B) to (D) Point 2
 Point 3 Mapping - Connects (A) to (B) to (E) Point 3
 Point 4 Mapping - Connects (B) to (A) to (F) Point 4



DVC-KD or Annunciator at Node 3

Figure B.7 Point Programming for Figure B.6

This setup would operate as follows:

1. A firefighter jacks in at (C). Point 1 rings at (A), and both LEDs flash. The operator presses Point 1, turning on the point. The point active LED will light steady on, and the yellow LED will turn off. Communication is established between the field telephone at (C) and the local telephone at (A).
2. A firefighter jacks in at (F). Point 4 rings at (A), the point active LED lights steady, and the yellow LED flashes. The operator presses Point 4, turning on the point. The yellow LED will turn off. Communication is established between the field telephones at (F) and (C).
3. (C) and (F) jack out. The operator presses Points 1 and 4 to terminate these connections. The FFT-NFN link automatically terminates, because no FFT-NFN programmed points remain active on it.

Example 4

Refer to Figures B.8 and B.9 for this example.

A DVC can communicate directly with another DVC via the FFT-NFN connection. The local phone at one DVC node can be connected to another: the link between DVC (A) and DVC (B) (the FFT-NFN link on Noti•Fire•Net).

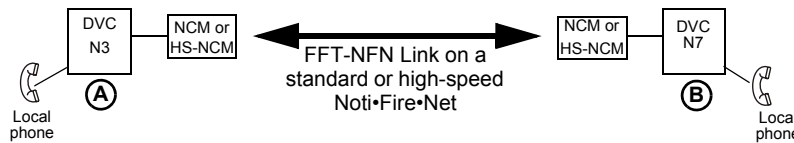
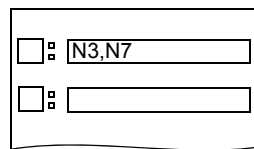

Figure B.8 FFT-NFN Communication Links Example 4

DVC-KD or annunciator points are required to establish and terminate this communication. These points must be programmed with the ACS function/mode "FFT-NFN". Figure B.9 shows the point programming. There must be a programmed point at each DVC for this link to function.

DVC-KD or ACS programming:
 ACS function/mode = **FFT-NFN**
 Mapping: as indicated in point label



DVC-KD or Annunciator at Node 3

Point 1 Mapping - Connects (A) to (B)

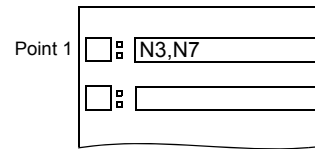

DVC-KD or Annunciator at Node 7

Figure B.9 Point Programming for Figure B.8 Example

This setup would operate as follows:

1. The DVC operator at node 3 (A) picks up the local DVC telephone and presses Point 1, turning on the point and making the FFT-NFN connection. The local DVC telephone at node 7 (B) rings, and both LEDs flash.
2. The DVC operator at node 7 (B) answers by picking up the phone and pressing Point 1 to speak. (A) and (B) are now in communication over the FFT-NFN link. The point active LEDs at both points light steady, and the yellow LEDs turn off.
3. To end the connection, one of the operators presses the Point 1 button to disconnect the FFT-NFN link.

Appendix C: Trouble Messages

Tables C.1 and C.2 list and describe the system and point trouble messages that can be generated by a DVC and its DAL (digital audio loop) devices. These messages pass along the wire or fiber DAL to the DVC, then to a panel network annunciator or workstation, to display as a trouble. System troubles can be used in logic equations (see “Logic Equations Branch” on page 66): the system trouble index number is listed next to each system trouble in Table C.1 for this function.

A DAA can also send trouble messages to the panel, network annunciator, or workstation through its trouble relay. The trouble relay sends a general trouble message to the panel, and the trouble must then be investigated at the DAA by checking the LED indicators. The trouble relay is used mainly as a backup in the event the monitoring panel loses communication with the DVC over a standard or high-speed Noti•Fire•Net.

The specific trouble message generated by the device appears on the panel or network annunciator’s screen as a trouble. The specific trouble message displayed will identify the digital audio component that generated it by displaying its address: the network node number of the DVC, next the device’s DAL address (1 - 32), if applicable. If the trouble is a speaker circuit trouble, the address will also contain the speaker circuit. The format will be AxxSz, where xx is the digital amplifier address, and z is the speaker circuit number .



NOTE: If the DVC is directly connected to an NFS2-3030 (that is, they are not connected through a network communication module), the NFS2-3030 will display specific troubles. An NFS2-640 will require a network annunciator to view DAL device troubles.

When the DVC is a node on a standard or high-speed Noti•Fire•Net, specific troubles will display at the network annunciator, workstation, or NFS2-3030 running in “Network Display Mode”.

System Trouble	Description	To Resolve	System Trouble Index Number
AC FAIL	Loss of AC power. Note: When AC power is lost, the DAL device does not broadcast non-emergency backup tones.	Investigate whether there is an AC power loss, or whether the power supply is correctly installed and wired.	1
ALARM SIGNAL	An Alarm Signal has been performed on the network.	Perform a Network Reset to clear the Alarm Signal.	725
AMPLIFIER LIMIT	The DAA, DAA2 or DAX is overloaded. The audio output will be distorted.	Remove outputs to lower the load on the speaker circuits. If the problem persists, call Technical Services.	590
AMPLIFIER SUPERVISION	The DAA, DAA2 or DAX amplifier’s internal supervision has identified a failure.	Ensure the amplifier is playing audio of sufficient amplitude or is idle. If the problem persists, call Technical Services.	591
ANALOG OUTPUT x TROUBLE	A trouble has occurred on DVC-AO analog output x (1-4). The analog output is configured for Class X, but no audio signal is returned.	Investigate and fix.	584 (1) 585 (2) 586 (3) 587 (4)
AUDIO LIBRARY CORRUPTED	The audio library is corrupt.	The database and audio library must be re-downloaded. If the trouble still does not clear, call Technical Services.	605
AUDIO LIBRARY INCOMPATIBLE	The audio library is not compatible with the programming database.	Check the version in VeriFire Tools. Correct and re-download the database and audio library.	607
AUXIN TROUBLE	This trouble will be generated when the auxiliary input is supervised (as determined by VeriFire Tools programming) and insufficient signal is detected on the input.	Check the wiring and source.	575
BACKUP AMP LIMIT	The BDA on a DAA2 or DAX is overloaded. The audio will be distorted.	Remove outputs to lower the load on the speaker circuits. If the problem persists, call Technical Services	630
BACKUP AMP NOT INSTALLED	The database has a BDA programmed for that address but it is either disconnected or configured incorrectly.	Confirm it is the correct product attached. Investigate the cable harnesses to make sure both are connected. Check the switch settings for proper adjustments.	679
BACKUP AMP \underline{x} FAIL	Internal supervision is not working on the DS-DB backup input \underline{x} (1-4).	Ensure the amplifier is playing audio of sufficient amplitude or is idle, and the wiring is correct. If the problem does not clear, call Technical Services.	675 (1) 676 (2) 677 (3) 678 (4)

Table C.1 System Trouble Messages

System Trouble	Description	To Resolve	System Trouble Index Number
BACKUP AMP <u>x</u> HARDWARE FAIL	The DS-BDA at DS-BUS address <u>x</u> (1-4) is not functioning correctly.	Contact Customer Service for replacement.	620 (1) 621 (2) 623 (3) 624 (4)
BACKUP AMP <u>x</u> LIMIT	The DS-BDA at DS-BUS address <u>x</u> (1-4) is overloaded. The audio will be distorted.	Remove outputs to lower the load on the speaker circuits. Ensure the wiring is correct. If the problem persists, call Technical Services.	635 (1) 636 (2) 637 (3) 638 (4)
BACKUP AMP <u>x</u> NOT INSTALLED	The database has a DS-BDA at DS-BUS address <u>x</u> (1-4) and it is disconnected or defective.	Confirm the DS-BDA has power. Investigate the cable harnesses to make sure both are connected.	680 (1) 681 (2) 682 (3) 683 (4)
BACKUP AMP <u>x</u> OVERCURRENT	The DS-BDA at DS-BUS address <u>x</u> (1-4) is drawing more current from the power supply than expected, but is still in operation.	Removed outputs to lower the load on the speaker circuits. Ensure the DS-BDA is programmed to the same group as the DS-AMP and wired correctly.	643 (1) 644 (2) 645 (3) 646 (4)
BACKUP AMP <u>x</u> TRIP	The DS-BDA at DS-BUS address <u>x</u> (1-4) is drawing more current from the power supply than expected, and has been disabled.	Remove outputs to lower the load on the speaker circuits. Ensure the DS-BDA is programmed and wired to the same group as the DS-AMP. Press TEST on the DS-DB to clear the trip. If the trouble returns, contact Technical Services.	651 (1) 652 (2) 653 (3) 654 (4)
BATTERY	The amplifier's battery voltage is too high or too low.	Check the batteries for problems. Replace batteries if necessary.	2
BUZZER OFF-LINE	The DVC's piezo is disabled.	Re-enable the piezo at switch 5.	201
CHARGER FAIL	The amplifier's battery charger is not functioning.	Investigate and correct the charger problem.	83
DAL ADDRESS CONFLICT	More than one DAL device has the same address.	Re-address DAL device(s).	592
DAL DOWNLOAD IN PROGRESS	The DVC is currently downloading to a DAL device.	n/a	608
DAL NO ANSWER	The DAL device is not communicating.	The DAL device address will display at the panel or network level. Check for proper address settings on the unit and confirm the unit is powered and operational.	615
DAP PORT <u>x</u> FAILURE	Digital Audio Port <u>x</u> (A or B), wire or fiber, is not communicating due to a break in the connection, a short, or faulty hardware.	Locate and fix the break or short. If the problem is not a short or break, contact Customer Service for replacement.	579 (Port A) 580 (Port B)
DATABASE CORRUPTED	The database that houses the DVC/DAL device programming is corrupt.	The database must be re-downloaded, or all programming must be cleared and re-entered. If the trouble still does not clear, call Technical Services.	604
DATABASE INCOMPATIBLE	The programming database version is not compatible with application version.	The correct application or version must be downloaded.	606
DSBUS <u>x</u> AC FAIL	DS-BUS device at address <u>x</u> (1-4) has a loss of AC power.	Investigate whether there is an AC power loss, or whether the power supply is correctly wired.	655 (1) 656 (2) 657 (3) 658 (4)
DS-BUS <u>x</u> COMMUNICATIONS FAILURE	There is a communication failure at the DS-AMP amplifier at address <u>x</u> (address determined by the address switch setting at the amplifier).	Investigate the DS-BUS connections.	624 (1) 625 (2) 626 (3) 627 (4)

Table C.1 System Trouble Messages

System Trouble	Description	To Resolve	System Trouble Index Number
DSBUS \underline{x} LOW BATT	DS-BUS device at address \underline{x} (1-4) has batteries that are too low.	Confirm that a power supply capable of charging batteries is attached. Check the batteries for problems. Replace batteries if necessary.	663 (1) 664 (2) 665 (3) 666 (4)
DSBUS \underline{x} HIGH BATT	DS-BUS device at address \underline{x} (1-4) has batteries that are too high.	Check the batteries or charger for problems. Replace batteries if necessary.	659 (1) 660 (2) 661 (3) 662 (4)
DSBUS \underline{x} SELF TEST FAIL	DS-BUS device at address \underline{x} (1-4) failed a diagnostic test.	Contact Customer Service for replacement.	667 (1) 668 (2) 669 (3) 670 (4)
DVC COMM LOSS	The DAL device is not in communication with the DVC.	The DVC will generate a DAL NO ANSWER error to the panel or network annunciator for investigation.	245
EXCEEDED CONNECTION LIMIT	The high-speed NCM has exceeded its limit of 2 devices connected to its NUP and USB ports.	Remove the additional node from the HS-NCM.	613
EXTERNAL RAM ERROR	The internal RAM test failed on the DVC or DAL device.	Contact Customer Service for replacement.	9
FLASH IMAGE ERROR	The DVC or DAL device software is corrupt.	Re-download the DVC/DAL device code software from VeriFire Tools. If the trouble still does not clear, call Technical Services.	588
GENERAL PS FAULT	General fault from the power supply at the indicated address.	Refer to the power supply's manual. For example, if the power supply is an AMPS-24, refer to its manual, p/n 51907.	232
GROUND FAULT	There is a general ground fault on the DAL device other than at Digital Audio Port A (DAPA) or Auxiliary input A.	Locate and fix the ground fault.	0
GROUND FAULT PORT \underline{x}	A ground fault has occurred on Digital Audio Port (DAP) \underline{x} . Wire versions only.	Locate the ground fault and repair.	572 (Port A) 573 (Port B)
HARDWARE MISMATCH	The DAL device at a particular address does not match the database selection.	Confirm the address on the DAL unit and check the database setting. Re-download the database if necessary.	614
HS-NCM SNIFFER MODE ACTIVE	HS-NCM is in a network diagnostic mode	Cycle power on the HS-NCM or call technical services.	612
LOADING....NO SERVICE	The DVC or DAL device is in bootloader mode. The DVC/DAL device is NOT providing fire protection communication while this trouble is active.	Proper authorities should be notified while this trouble is active so that other means of fire protection can be supplied, if necessary.	91
LOCAL MIC TROUBLE	The local microphone is in trouble. There is no communication, or paging has been enabled for over 17 seconds and no signal has been received.	Investigate whether the microphone is plugged in, or whether there is a problem with the local microphone.	582
LOCAL PHONE TROUBLE	The local FFT handset is in trouble. There is either a failure with the local handset, or paging from FFT has been enabled for over 17 seconds and no signal has been received.	Investigate whether the handset is plugged into the DVC, or whether there is a problem with the handset.	583
MAN EVAC RECEIVED	A network drill has been initiated.	Perform a network reset to clear the drill.	109
MAX NFN CHANNEL LIMIT	A DVC is attempting to page to the NFN network that is already in use with a page of higher or equal priority.	Reduce the number of DVCs attempting to page over the NFN. NFN only supports one channel at a time.	629
NCM COMM FAILURE	Communication lost between NCM/HS-NCM and the DVC.	Investigate cause and restore communication.	211

Table C.1 System Trouble Messages

System Trouble	Description	To Resolve	System Trouble Index Number
NETWORK FAIL PORT \underline{x}	Communication lost between standard or high-speed Noti•Fire•Net Port \underline{x} and corresponding node.	Investigate the cause and restore communication.	79 (Port A) 80 (Port B)
NFPA 24HR REMINDER	Daily reminder of unresolved troubles.	Acknowledge reminder.	93
NVRAM BATT TROUBLE	Battery backup and/or clock backup is low.	Replace the battery.	94
PHONE CHANNEL LIMIT EXCEEDED	The digital bandwidth of the FFT system has been exceeded.	Turn off unused telephone points, reduce the number of active risers on a DVC/DAL network to 5 or less.	611
POWER SUPPLY COMM FAILURE	There is a communication failure with the DS-DB external power supply on the DS-BUS.	Investigate the cause at the power supply and cable. Verify the power supply is programmed to the proper communications settings.	449
POWER SUPPLY TROUBLE	There is a communication failure between the DAA lower board and its upper power supply board, or between the DAA2 lower board and its upper CPS-24 power supply board.	Contact Customer Service for replacement.	589
PRIMARY AMP \underline{x} FAIL	Internal supervision is not working on amplifier \underline{x} (For a DS-DB, $x =$ DS-DB primary input 1-4. For a DAA2 or DAX, $x =$ 1 for the primary amplifier, 2 for the BDA.).	Ensure the amplifier is playing audio of sufficient amplitude or is idle. For a DS-DB, ensure the wiring is correct. If the problem does not clear, call Technical Services.	671 (1) 672 (2) 673 (3) 674 (4)
PRIMARY AMP \underline{x} HARDWARE FAIL	The DS-AMP at DS-BUS address \underline{x} (1-4) is not functioning correctly.	Contact Customer Service for replacement.	616 (1) 617 (2) 618 (3) 619 (4)
PRIMARY AMP \underline{x} LIMIT	The DS-AMP at DS-BUS address \underline{x} (1-4) is overloaded.	Remove outputs to lower the load on the speaker circuits.	631 (1) 632 (2) 633 (3) 634 (4)
PRIMARY AMP \underline{x} OVERCURRENT	The DS-AMP at DS-BUS address \underline{x} (1-4) is drawing more current than expected, but is still in operation.	Remove outputs to lower the load on the speaker circuits. Ensure the BDA is programmed to the same group as the DS-AMP and wired correctly.	639 (1) 640 (2) 641 (3) 642 (4)
PRIMARY AMP \underline{x} TRIP	The DS-AMP at DS-BUS address \underline{x} (1-4) is drawing more current than expected, and has been disabled.	Remove outputs to lower the load on the speaker circuits. Press TEST on the DS-DB to clear the trip. If the trouble returns, contact Technical Services.	647 (1) 648 (2) 649 (3) 650 (4)
REMOTE MIC TROUBLE	The remote microphone is in trouble. It is installed and supervised, but no signal is coming from it.	Investigate and fix. Inspect wiring, microphone connection, termination.	578
SELF TEST FAILED	Diagnostic test failed.	Reboot the unit. If the problem does not clear, contact Customer Service for replacement.	250
SOFTWARE MISMATCH	The DAL device has a software revision that is incompatible with the DVC's software.	Correct the software revision.	503

Table C.1 System Trouble Messages

Point	Point Trouble	Description	To Resolve
Speaker	OPEN CIRCUIT	There is a break in the wiring of a speaker circuit.	Verify the proper ELR and investigate for a break.
Speaker	SHORT CIRCUIT	There is a short circuit between the output and input of the speaker circuit.	Investigate for a short or for Class wiring getting crossed between output and input.

Table C.2 Point Trouble Messages

Point	Point Trouble	Description	To Resolve
FFT Riser	OPEN CIRCUIT	There is a break in the wiring of an FFT riser.	Verify the proper ELR and investigate for a break.
FFT	SHORT CIRCUIT	There is a short circuit between the output and input of the speaker circuit.	Investigate for a short or for Class wiring getting crossed between output and input.

Table C.2 Point Trouble Messages

Appendix D: Audio Groups

D.1 Overview

An audio group consists of a collection of speaker circuits on a single DS-DB or DAA2 with one or more amplifiers assigned to it. A group can be as small as one amplifier and one speaker circuit, or as large (if you use a DS-DB) as four amplifiers and eight speaker circuits. A DAA2 can have up to two groups: a DS-DB can have up to four groups. Implementing groups eliminates the possibility of overloading amplifiers while retaining flexibility that covers most applications. Group elements are linked through VeriFire Tools programming.

The number of channels a group can play is limited by the number of amplifiers assigned to the group. For example, a group that consists of a DAA2 and its four speaker circuits with no BDA acting as a second channel will only be able to play one channel at a time. A group that consists of a DAA2, BDA used as a second channel, and speaker circuits would be able to play two channels simultaneously.

Refer to the programming section of the Digital Voice Command manual or the VeriFire Tools Help file for programming instructions for groups.

D.2 Examples

D.2.1 One Amplifier Per Group

The group examples in this section are single-channel group configurations. Each group can use only one of the digital audio system's eight channels at a time.

1. Figure D.1 shows a DS-DB with four groups. Each of the DS-DB amplifiers (all DS-AMP's in this example) is in a group with a single speaker circuit that has a load not exceeding the amplifier's 120 watt capacity.

Each group can play one message at a time. Since there are four groups, each capable of broadcasting a single channel, this DS-DB system can broadcast up to four different messages at a time.

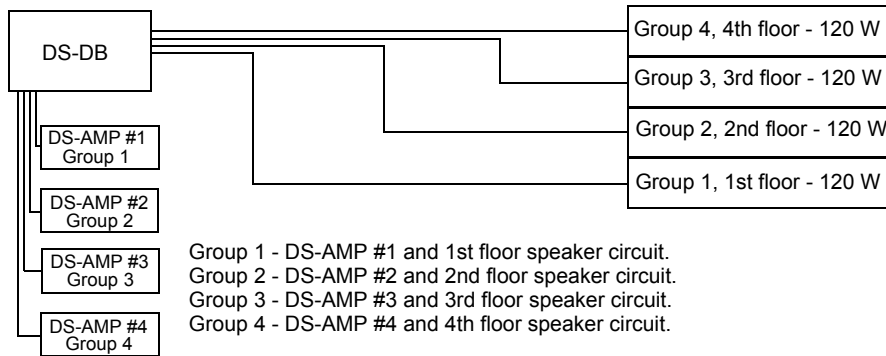

Figure D.1 DS-DB, One Amplifier and One Speaker Circuit per Group, No BDAs

2. Figure D.2 shows a group that consists of a DAA2 amplifier and all its speaker circuits. The load on all four speaker circuits does not exceed the DAA2's 50 watt capacity. This group is capable of broadcasting one channel at a time.

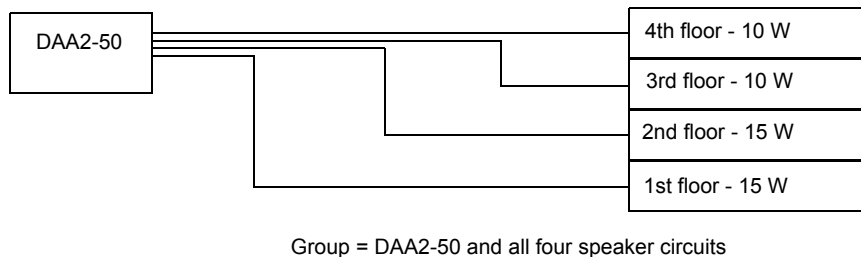
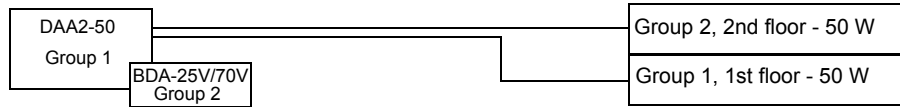

Figure D.2 DAA2 - One Amplifier and All Speaker Circuits per Group, No BDA

- Figure D.3 shows a DAA2 with a BDA used as a primary amplifier. Each amplifier is in a separate group with a speaker circuit. Each amplifier supports a 50 watt load, and each group can play one message at a time. The DAA2's battery charger will be disabled automatically.



Group 1 - DAA2-50 and 1st floor speaker circuit.
 Group 2 - BDA-25V/70V (used as a primary amp) and 2nd floor speaker circuit.

Figure D.3 DAA2 - One Amplifier, One Speaker Circuit per Group, BDA

- Figure D.4 shows a DS-DB with one group. The DS-AMP amplifier is in a group with all eight of the DS-DB's speaker circuits. The load on all eight circuits does not exceed the DS-AMP's capacity of 120 watts. Since the group has one amplifier, capable of broadcasting a single channel, this DS-DB system can broadcast one channel at a time.

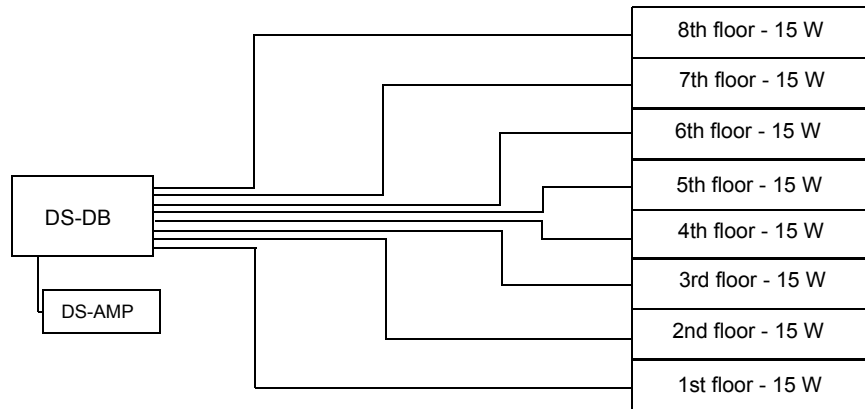

Group = DS-AMP and all eight speaker circuits.

Figure D.4 DS-DB - One Amplifier per Group, All Speaker Circuits

- Figure D.5 shows a DS-DB with four groups. Each DS-AMP amplifier is in a group with speaker circuits whose load does not exceed the amplifier's 120 watt capacity. Since there are four groups, each capable of broadcasting a single channel, the DS-DB can broadcast up to four different messages simultaneously. Not all the outputs in each group have to activate at the same time; for instance, in group 4, the speaker circuit for the 7th floor could remain inactive while the 6th and 5th floors broadcast, but the 6th and 5th floors would broadcast the same message from a single channel.

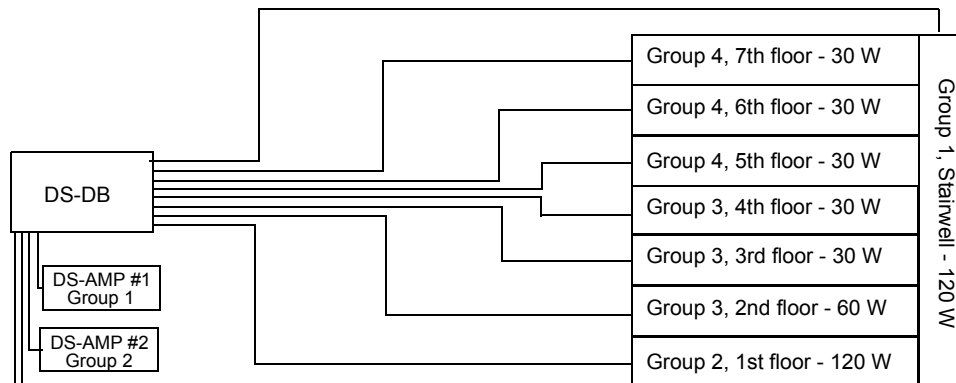

Group 1 - DS-AMP #1 and stairwell speaker circuit.
 Group 2 - DS-AMP #2 and 1st floor speaker circuit.
 Group 3 - DS-AMP #3 and 2nd, 3rd and 4th floor speaker circuits.
 Group 4 - DS-AMP #4 and 5th, 6th and 7th floor speaker circuit.

Figure D.5 DS-DB - One Amplifier per Group, Various Speaker Circuit Configurations

D.2.2 Multiple Amplifiers Per Group

The examples in these configurations are capable of multi-channel operation within a group, using more than one of the digital audio system's eight channels at a time.

- Figure D.6 shows a DS-DB with one group that is assigned two DS-AMP amplifiers. The group contains speaker circuits with loads that do not exceed the capacity of a single amplifier in the group (in this case, 120 watts).
Because two amplifiers are grouped with multiple speaker circuits, the group is capable of broadcasting two channels simultaneously. In the example below, EVAC is broadcast through one amplifier, ALERT through the other, while some speaker circuits in the group do not broadcast.

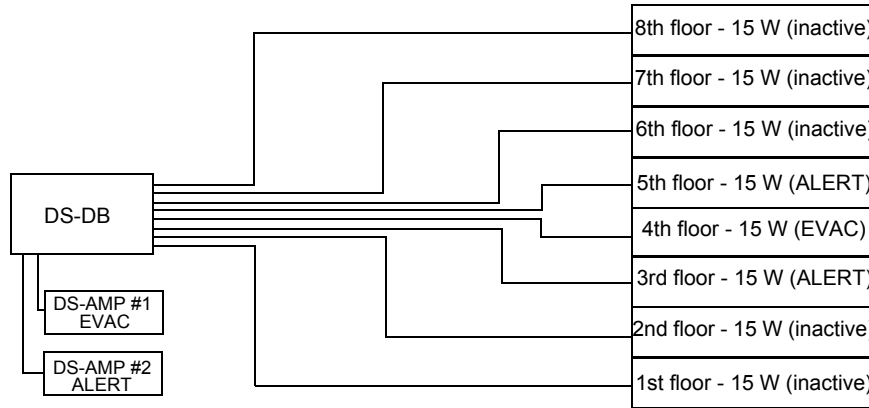

Group = DS-AMP #1 and #2, and all speaker circuits.

Figure D.6 DS-DB - Two-channel System

- Figure D.7 shows a DS-DB with two groups. Group 1 is assigned three DS-AMP amplifiers. Group 2 is assigned one DS-AMP amplifier. Each group contains speaker circuits with loads that do not exceed the capacity of a single amplifier in the group (in this case, 120 watts for group 1, and 20 watts for group 2).
Group 1 is configured for multi-channel use, and is capable of broadcasting three channels simultaneously. Group 2 has one amplifier assigned, and so is capable of broadcasting one channel. This DS-DB system is altogether capable of broadcasting four channels simultaneously. Group 1 is performing the following functions: FIRE is broadcast through one amplifier, another amplifier broadcasts to the floor above, one amplifier broadcasts to the floor below, while some speaker circuits are inactive. Group 2 broadcasts a single channel to the stairwell speaker circuit.

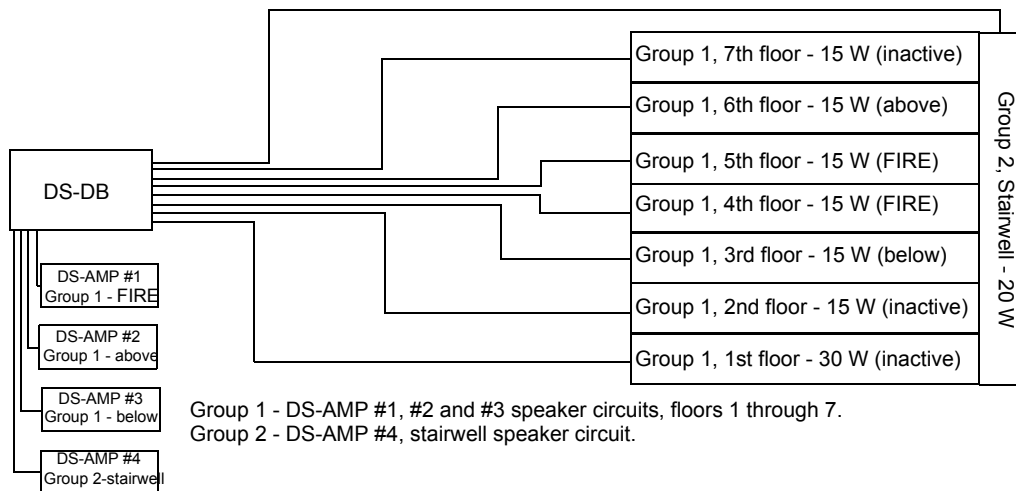

Group 1 - DS-AMP #1, #2 and #3 speaker circuits, floors 1 through 7.
Group 2 - DS-AMP #4, stairwell speaker circuit.

Figure D.7 Three-channel System

- Figure D.8 shows a two-channel system with a DAA2 and BDA in the same group. The group contains speaker circuit loads that do not exceed the capacity of a single amplifier (50 watts in this example).
Because the two primary amplifiers are in the same group along with multiple speaker circuits, the group is capable of broadcasting two channels simultaneously. In the example below, EVAC is broadcast through one amplifier, ALERT through the other, while some speaker circuits in the group do not broadcast.

The DAA2 has full battery charging capabilities.

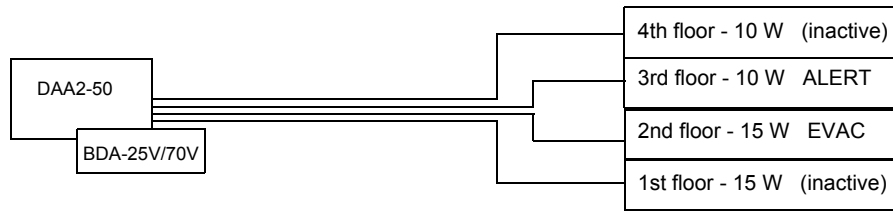

Group = DAA2-50, BDA-25V/70V as a primary amplifier, and all speaker circuits

Figure D.8 DAA2 - Two-channel System

D.3 Rules

DAA2 and DS-DB amplifiers and speaker circuits must be assigned to groups in VeriFire Tools programming. In order to assign them properly, apply the following rules.

- *The sum of the load (in watts) of the group must be equal to or less than the wattage of a single amplifier in that group.*
An amplifier must be capable of supporting the entire group of speaker circuits. For example, a DS-AMP by itself can support a group of up to 120 watts of speaker load.
- *Groups can not overlap. A speaker circuit can not be assigned to more than one group.*
- *A group may not be assigned to more than one DS-DB or DAA2. It can not bridge between DS-DBs and/or DAA2s.*
- *At least one amplifier is required for each channel that will be played simultaneously with another channel in the group.*
For example, if ALERT and EVAC channels will be played at the same time in a group, at least two amplifiers are necessary.
- *If a DS-BDA is used as a primary, it must be in the same group as its DS-AMP.*

Appendix E: DVC MN Modes

When the DVC is set to an MN Mode of ACU, LOC, CCS, or Subsidiary (see “General Settings Tab, Column 3” on page 46, DVC MN Mode section):

- The first column will not have an Enable Telephone Page button.
- The second column will use the top three buttons for different level All Calls, and quick paging may be performed, for the ACU, LOC, and CCS. All Call levels are not enabled for a Subsidiary DVC.
- For the ACU, LOC, and CCS, the microphone will use MN inputs (see Table 3.4, “First 14 Default Input Priorities (DVC Configured for Mass Notification),” on page 62.)

All other DVC functions remain the same: auxiliary inputs, remote microphone interface, alarm bus, FFT riser and DVC-AO board are still available for use.

E.1 DVC-KD Installation

The DVC-KD is installed per instructions on page 27. The two right-column slide-in labels will also be the same. The two left columns use label 50116871 in the left-most column, and label 50107432-001 must be used in the second column.

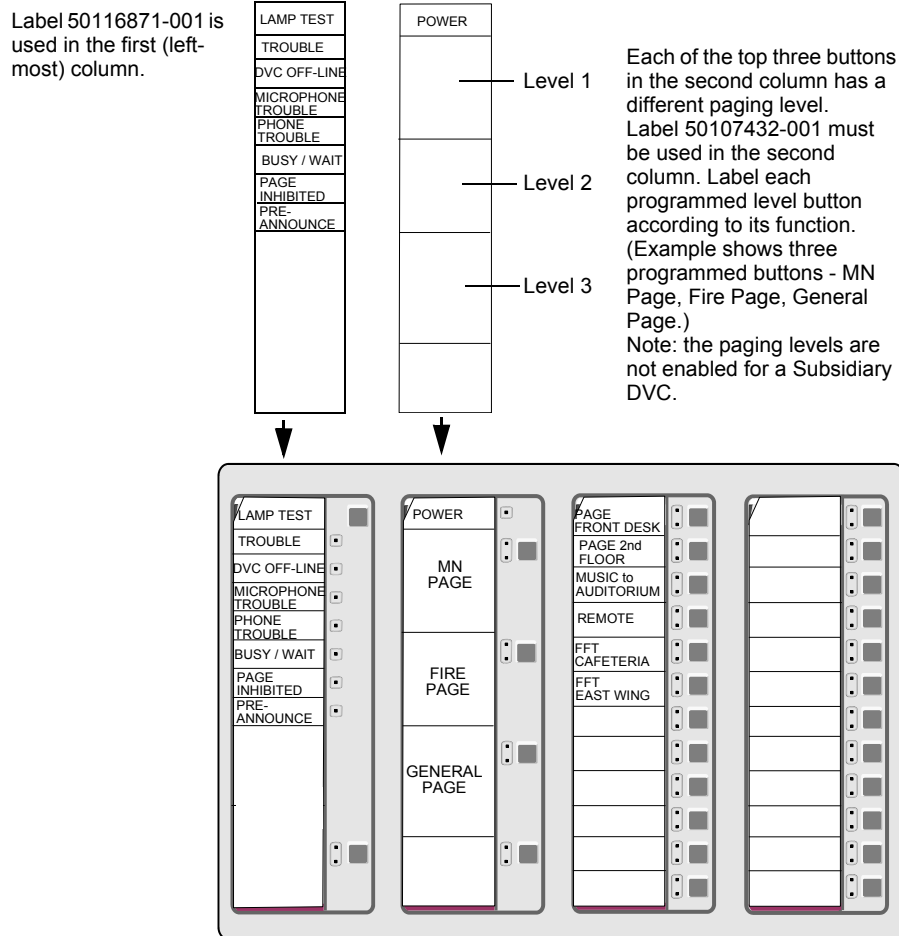

Figure E.1 DVC-KD Keypad, ACU, LOC or CCS Mode

E.2 Programming

VeriFire Tools is used to set the DVC mode, and paging types must be selected. Refer to the DVC MNS Mode section in “General Settings Tab, Column 3” on page 46 for instructions.

Glossary

A

All Call Paging to audio outputs mapped to the DVC-KD ALL CALL button, or to a user-programmable DVC-KD button with its function set to ALL CALL.

Audio Command Center Comprised of a DVC, DVC-KD and NCA-2 or NFS2-3030, an audio command center accepts live paging from several sources, provides the ability to direct paging to pre-programmed speaker zones.

C

Control Module An addressable module that a) switches power to a Class A or Class B NAC, or b) functions as a Form-C control relay.

Control-by-Event A software function that provides a means to program a variety of output responses based on various initiating events. Networked CBE is sometimes referred to as CCBE (Cooperative Control-by-Event).

D

DAL (Digital Audio Loop) Comprised of a DVC, digital audio devices, and the wire or fiber between them connected at the digital audio ports.

DCC (Display and Control Center) A display location, programmed to participate in DCC, when it has control of Acknowledge, Signal Silence, System Reset, Drill (Alarm Signal for Canadian applications), and network paging functions.

F

FFT Firefighter's telephone.

H

High Quality Audio 44.1 kHz sampling rate, 16 bit PCM, mono.

L

Logic Equation Programmed expression of initiating events that provides the means to trigger various output events. A logic zone consists of a logic equation.

M

Message Segment A .wav file used to create an audio message sequence for alert, evacuation, or other messages. The .wav is either provided by the sound library supplied with VeriFire Tools or created by the user.

Message Sequence An audio message sequence comprised of at least one audio message segment and the commands to govern its broadcast.

N

Node Equipment that connects to Noti•Fire•Net and communicates with other equipment using that network may be referred to as a node. The minimum hardware requirement for Noti•Fire•Net is two nodes connected via wire or fiber optic cable.

P

PAM point Address of the intersection between an audio input and output in the Prioritized Audio Matrix. When a PAM point is activated the input will broadcast on its outputs.

Prioritized Audio Matrix (PAM) Database section of the DVC programmed to link prioritized audio inputs to audio outputs.

S

SPECIAL PAGING FUNCTIONS Paging to audio outputs mapped to the PAGE ACTIVE EVAC AREAS, PAGE ACTIVE ALERT AREAS, and PAGE INACTIVE AREAS buttons on the DVC-KD.

Standard Quality Audio 11.025 kHz sampling rate, 8 bit μ -law, mono.

V

VeriFire Tools A software program utility for uploading and downloading system programming and databases between a personal computer and the control panel through compatible ports.

Notes

Notes

Index

Numerics

- 24VDC Power
 - Specifications **16**
 - Wiring **30**
- 4WIRE Switch **40**

A

- AA Series analog audio amplifiers **37**
- AA-100/AA-100E **15, 39**
- AA-120/AA-120E **15, 39**
- AA-30/AA-30E **15, 39**
- AC FAIL and non-emergency backup tones **81**
- ACT-25 **39, 53**
- ACT-4 **37**
- ACT-70 **53**
- Activating a PAM Point **62**
- Active Tone, see Mass Notification System Manual
- ADDR-B4/R door **23**
- ADDR-C4/R door **23**
- ADDR-D4/R door **23**
- Addressing a PAM Point **62**
- AFAWS **34**
- Alarm Bus
 - Specifications **16**
 - Wiring **31**
- ALL CALL
 - Programming **46**
- All Call Mapping **46**
- AMG-1 **9**
- Amplifier Field Definitions **52**
- Amplifier Programming Options **51**
- AMPS-24/E **34**
- Application Block Diagrams **14**
- Audio
 - groups **86**
 - high quality **13, 44, 45**
 - standard quality **13, 44**
- Audio command center **13, 15, 23, 70**
- Audio Message Programming **57**
 - See also "Programming, Audio Messages"
- Audio Settings Branch **57**
- Audio storage
 - DVC **13, 44**
 - DVC-EM **13, 44**
- Auxiliary Input A (AUX A)
 - Default Input Priority **61**
 - Paging **73**
 - Signal Supervision option **35, 45**
 - Specifications **16**
 - VeriFire Tools Programming **52**
 - Wiring **34**
- Auxiliary Input B (AUX B)
 - Default Input Priority **61**
 - Paging **73**
 - Signal Supervision option **35, 45**
 - Specifications **16**
 - Wiring **35**

B

- Backup Tones **45**
- Battery, Lithium
 - location and alignment
 - DVC **17**
 - replacement procedure
 - DVC **39**
- BDA **13, 52, 53, 86, 88, 89**

C

- CA-1 Chassis **23**
 - Mounting **28**
 - Sliding CMIC-1 for Wiring Access **29**
- CA-2 Chassis **23**
 - Mounting **28**
 - Sliding chassis aside for Wiring Access **30**
- CAB-4 Series Cabinets **23**
- Canadian Operations **46**
- Canadian Room Isolator Modules, programming **53**
- CAUTION
 - Certain modifications will delete all PAM points and audio messaging information. **45**
 - Changing wiring class configuration may delete some speaker points. **53**
 - FFT-NFN Priority **60**
 - Re-secure hex nuts to prevent equipment damage. **29, 30**
- CFFT-1 **23, 29**
- Channels, number of on DAL **15**
- Chassis
 - See CA-1
 - See CA-2
 - See CFFT-1
 - See CHS-BH1
- CMIC-1 **23**
 - Sliding for Wiring Access **29**
- Configuration Switches
 - 4WIRE **40**
 - Piezo **40**
 - Setting **40**
- Connector pins
 - DVC-AO **26**
 - DVC-KD **27**
- Control-By-Event **66**
- Controls Active panel LED **73**
 - create a segment file **57**

D

- DAA **13, 28, 34, 45, 52, 53, 62, 69, 77**
- DAA2 **13, 32, 51, 52, 53, 69, 75, 76, 86**
- DAL **13, 32**
 - Earth fault detection **74**
 - Mapping **50**
 - Number of Channels **15**
- DAL Device Alarm Bus Activation **68**
- DAL Mapping branch **50**
- DAPs
 - Class B, Class X **32**

- Specifications **16**
 - Wiring **32**
- data-entry grid **42**
- DAX **13, 32, 51, 52, 53, 69, 75**
- DCC **15, 73**
 - Settings **46**
- Default Input Priorities **61**
- Default Input Priorities, MNS **62**
- Digital Audio Loop, See DAL
- Digital Audio Ports, see DAPs
- Display and Control Center, see DCC
- DPA-1 dress panel **23**
- DPA-1A4 dress panel **23**
- DPA-2 dress panel **23**
- DS-AMP **13, 86, 87, 88, 89**
- DS-BDA **89**
- DS-DB **13, 32, 52, 53, 54, 55, 69, 86**
- DS-DB Field Definitions **54**
- DS-DB General Settings Tab **54**
- DS-DB Groups Tab **55**
- DS-DB Low-Level Output Tab **54**
- DS-DB Speaker Circuit Settings Tab **55**
- DS-RFM **21**
- DVC
 - Board Layout, wire **17**
 - Node number assignment **41**
 - See also "Programming, DVC"
 - Specifications **16**
- DVC Inputs Branch **59**
- DVC-AO **15**
 - Board Layout **20**
 - Mounting to DVC **26**
 - Specifications **17**
 - Wiring **37**
- DVC-EM
 - Audio Storage **44**
 - Board Layout, wire **17**
 - Specifications **16**
 - VeriFire Tools Programming **43**
- DVC-KD **15, 20**
 - Indicators **70**
 - Labels **27**
 - Mapping **48, 55**
 - Mounting to DVC **27**
 - Operation **70**
 - Pre-defined Buttons **70**
 - Slide-in labels **27**
- DVC-KD Point Mapping Syntax **49**
- DVC-RPU **13, 20, 55, 69**
- DVC-RPU Programming **55**

E

- Earth fault detection
 - DAL **74**
- Edit Session Tree **42**
- Edit session tree **40**

F

- FCM-1 **31**
- FFT

- Communication **76**
- Network and Examples **76–77**
- FFT Riser
 - NFPA Class A or B configuration **34**
 - DAA programming **52**
 - DS-DB programming **45, 54**
 - Specifications **16**
 - Wiring **34**
- FFT-NFN **77**
- Fire Active Tone, see Mass Notification System Manual
- FPJ-1 **34**
- FTM-1 **34**

G

- General Settings Branch **43**
- Goldwave software program **57**
- Groups, audio **86**

H

- High quality audio **13, 44**

I

- Input Priorities, Defaults, Fire System **61, 62**
- Installation **23**

K

- keypad
 - Mapping **55**
- Keypad, see DVC-KD

L

- LabelEase **27**
- Labels for DVC-KD keypad **27**
- LED Indicator
 - Descriptions **19**
 - DVC-KD **71**
 - Locations **18**
- Lithium Battery
 - See Battery, Lithium
- Local Control **44**
- Local Microphone Interface
 - Wiring **37**
- Local Phone Interface **37**
- Logic Equation
 - Branch **66**
 - Builder **66**
 - DAL Device Alarm Bus Activation **68**
 - Data-Entry Grid **66**
 - Edit and Save Changes **67**
 - Functions **67**
 - Logic Equation Commands **67**
 - Note on mapping **63**
 - Operands **67**
 - Operators **67**
 - PAM point activation **65**
 - Point Address Format **67**
 - Points **67**

M

- Mapping, DAL **50**
- Mass Notification **41**
- Media Interface Settings **45**
- Message Overrides **65**
- Message Segments **57**
 - Duration Time **58**
 - Library **57**
 - Number assignment **57**
- Message Sequences **58**
- Message Types **58**
- MIC-1 **23, 37**
 - Cable **37**
- MN Active Tone, see Mass Notification System Manual
- MN Mode **46**
- MNS Default Input Priorities **62**
- Multi-channel applications **47**

N

- NCA **9, 14**
- NCA-2 **30, 40, 62, 73**
- Network Connection Ports, see NUP Ports
- Network Control Module
 - Mounting in CA-1 or CA-2 **28**
- Network Paging **64**
- Network Paging, functional/programming overview **63**
- Networked System **14**
- NFN, FFT communication **77**
- NFS2-3030 **35, 40, 62, 65, 73, 81**
- NFS2-3030 single panel application **14**
- NFS2-640 **14, 35, 40, 65**
- NFS-3030 **9, 14**
- NFS-640 **9, 14**
- Node limitation on standard Noti•Fire•Net **15, 45**
- Node number assignment **41**
- Non-displayed Events **73**
- non-emergency backup tones **81**
- Noti•Fire•Net **34, 36, 68**
- NUP Ports **35**
- NVRAM battery
 - See Battery, Lithium

O

- Online Session Tree **42**
- Overrides, messages **65**

P

- Paging **72**
 - ALL CALL button **71**
 - AUXA and AUXB **73**
 - DVC-KD Inhibit **46**
 - FFT **73**
 - MIC-1 local mic **72**
 - Network **63**
 - PAGE ACTIVE ALERT AREAS button **71**
 - PAGE ACTIVE EVAC AREAS button **71**
 - PAGE INACTIVE AREAS button **71**
 - Page inhibit **46**

- RM-1 Remote Mic **72**
- TELH-1 local phone **72**
- Paging Level **46**
- PAM point
 - activation **62**
 - address **62**
 - Programming **62**
- PAM Point Programming **65**
- PAM Settings Branch **62**
- Piezo **40**
- Play commands **58**
- Point-to-point FFT communication over NFN **77**
- Programming **40**
 - ALL CALL **46**
 - Analog Output Wiring Class **44**
 - Audio Messages
 - Play Commands **58**
 - Segments **57**
 - Sequences **59**
 - Control-By-Event **66**
 - DAA
 - Backup Tones **45**
 - Battery Size **53**
 - Disable Charger **53**
 - FFT Riser **52**
 - FTM Modules Installed **52**
 - DAA2
 - Backup Tones **45**
 - Disable Charger **53**
 - FFT Riser **52**
 - FTM Modules Installed **52**
 - DAX
 - Backup Tones **45**
 - Disable Charger **53**
 - DCC **46**
 - DS-DB **53**
 - Backup Tones **45**
 - FFT Riser **52**
 - FTM Modules Installed **52, 54**
 - DVC
 - Expander Board **44**
 - FFT Riser **45**
 - Label **44**
 - Local Control **44**
 - Node number assignment **41**
 - DVC-KD **49**
 - DVC-KD key mapping **48**
 - DVC-RPU **55**
 - General zones **50**
 - Import .wav files into segment library **57**
 - Input Source
 - Default Priorities **61**
 - Fixed number **59**
 - Priority Number **59**
 - Labels **53**
 - Logic Equation Builder **66**
 - Mass Notification Control **46**
 - Microphones **44**
 - Node number assignment **41**
 - PAM (Prioritized Audio Matrix) **62**
 - PAM Point **65**
 - PAM Programming **62**

- Reports **69**
- Riser Modes **52, 54**
- Special function zones **68**
- TELH-1 local FFT **45**
- Validation **69**
- Push-to-talk Interface
 - Specifications **16**
 - Wiring **36**

Q

- Quick Paging **46**

R

- R-3.9k **16, 34**
- Read Status **73**
- Regional Setting **46**
 - Canada **46**
- Remote Microphone Interface
 - Specifications **16**
 - Wiring **36**
- Reports from VeriFire Tools **69**
- Resound PAM points **65**
- RM-1 **64**
- RM-1 Series microphone **36**
 - See also Remote Microphone Interface **36**
- Room Isolator Modules, Canadian, programming **53**
- RPU-PCC **55**

S

- Segments, Audio Message **57**
- Sequencing Audio Messages **58**
- Silenceable settings **65**
- Silenceable settings, PAM point **65**
- Single panel application, NFS2-3030, NFS2-640 **14**
- Single-channel applications **47**
- Special Function Zones **40, 68**
- SPECIAL PAGING FUNCTIONS
 - Programming **47**
- Special Paging Functions **46**
- Specifications
 - DVC **16**
 - DVC-AO **17**
 - DVC-AO, current draw **16**
 - DVC-KD, current draw **16**
 - RM-1, current draw **16**
- Standard quality audio **13, 44**
- Subsidiary **46**
- Supervision Programming
 - AUX A and AUX B **45, 52**
 - TELH-1 local phone **45**
- Switch Inhibit, PAM point **65**
- Switches **18**

T

- TELH-1 **23, 37, 45**
- Trouble messages **73**

U

- UL Power-limited Wiring Requirements **39**
- User-programmable Buttons **72**

V

- Validation, Program **69**
- VeriFire Tools Programming **40**
 - See also, "Programming"
- VeriFire Tools project **41**
- Volume Control, point programming **40**

W

- Wiring
 - 24VDC Power, DVC **30**
 - Alarm Bus **31**
 - Auxiliary Inputs A and B **34**
 - Digital Audio Ports A and B **32**
 - DVC-AO **37**
 - FFT Riser **34**
 - Local Microphone Interface **37**
 - Network Connection (NUP) Ports **35**
 - Push-to-talk Indicator **36**
 - Remote Microphone Interface **36**

DVC OPERATING INSTRUCTIONS

Section 1 Operating Conditions

Normal Standby Operation

1. Green POWER indicator lit steadily.
2. Yellow TROUBLE indicators off.
3. DVC OFF-LINE indicator is not lit, indicating the DVC is connected to the network.

When Audible Devices are Sounding for:

1. an Alarm Condition

- Evacuate the protected area.
- Notify the monitoring service and/or the Fire Department immediately. Tell them briefly what happened and what your current status is.
- Be prepared to provide directions to arriving firefighters.

2. **a Trouble Condition** - Activation of a trouble signal under normal operation indicates a condition that requires immediate attention. Contact your local service representative. Silence the piezo's audible signal by acknowledging the event at the DVC's panel or network annunciator. The trouble indicator will remain illuminated.

Section 2 To Page from the DVC

Fire System Only, Second Column Paging Buttons:

To page using the MIC-1 microphone or TELH-1 firefighter's telephone:

- Microphone: Press the push-to-talk button **after** pressing one of the paging buttons below.
- Telephone: Press the ENABLE TELEPHONE PAGE button **before** pressing one of the paging buttons below, then press the push-to-talk button.

ALL CALL

Press this button to initiate an ALL CALL page. After paging, press again to deactivate the microphone paging function. If the telephone paging function was selected, press the ENABLE TELEPHONE PAGE button to deactivate.

PAGE ACTIVE EVAC AREAS

Press this button to initiate a page to all zones designated as active evacuation areas. After paging, press this button again to deactivate the microphone paging function. If the telephone paging function was selected, press the ENABLE TELEPHONE PAGE button to deactivate.

PAGE ACTIVE ALERT AREAS

Press this button to initiate a page to all active zones designated as alert areas. After paging, press this button again to deactivate the microphone paging function. If the telephone paging function was selected, press the ENABLE TELEPHONE PAGE button to deactivate.

PAGE INACTIVE AREAS

Press this button to initiate a page to all inactive areas (that is, those outputs that are not broadcasting ALL CALL, ALERT, or EVAC messages. After paging, press this button again to deactivate the microphone paging function. If the telephone paging function was selected, press the ENABLE TELEPHONE PAGE button to deactivate.

Fire and Mass Notification System, Second Column Paging Buttons

To page using the MIC-1 microphone, press the push-to-talk button **after** pressing one of the paging buttons below. Paging access is indicated by a green light at the button pressed.

For MN pages, control is pre-determined by hierarchical priority programming. This DVC and its associated panel will take network control if there are no higher priority pages in progress: the panel's "Controls Active" LED lights and it will have sole access to Acknowledge, Silence and Reset functions. This control is relinquished back to the network when the page is completed. An in-progress page may be overridden by a higher-priority page.

(label, TOP BUTTON COLUMN 2)

Press this button to initiate an ALL CALL page at the highest priority level. If this button is designated for mass notification, a mass notification alarm will be generated by the page. After paging, press again to deactivate the microphone paging function.

(label, 2nd BUTTON COLUMN 2)

Press this button to initiate an ALL CALL page at the second highest priority level. If this button is designated for mass notification, a mass notification alarm will be generated by the page. After paging, press again to deactivate the microphone paging function.

(label, 3rd BUTTON COLUMN 2)

Press this button to initiate an ALL CALL page at the general priority level. After paging, press again to deactivate the microphone paging function.

Other Paging Areas

Press any button labeled for paging in the two right columns of the keypad to page the area designated by the label. Press again to deactivate the page function.

Section 3 To Enable FFT Communication and Paging

For buttons on the right half of this keypad or on local annunciators labeled as firefighter's telephone (FFT) points: Blinking LEDs at the button will indicate when a firefighter's telephone operator at a remote station is ringing in to this command center. Press the associated annunciator button to enable communication.

Fire System Only:

If the operator requests a paging function, press the ENABLE TELEPHONE PAGE button, then press the button for the type of paging desired (ALL CALL, etc.). Press the ENABLE TELEPHONE PAGE button again to end the page function.

Section 4 LED Indicators

Trouble - Illuminates during system initialization and when a DVC or one of its digital audio amplifiers generates a trouble. Specific trouble information will be displayed at the network annunciator or the DVC's standalone FACP.

DVC Offline - Illuminates when the DVC is not providing fire protection (for example, there is a problem with the DVC board).

DVC Microphone Trouble - Illuminates when a microphone page has been initiated, but no microphone activity has occurred for 28 seconds, or a connection failure exists.

DVC Telephone Trouble - Illuminates when a DVC telephone page has been initiated, but no telephone activity has occurred for 28 seconds, or a connection failure exists.

Busy/Wait - Illuminates when a code or database download from the DVC to its DAAs is in progress.

Page Inhibited - Another node has assumed paging control and locked out paging from this DVC.

Pre/post-announce Tone - Illuminates when the pre-announce or post-announce message is playing. Wait until this light goes off before paging.

Section 5 User-defined Buttons

The two right columns of the DVC keypad consist of user-defined inputs and outputs that act as annunciators. The labels identify the function.

To page to one of these areas, follow the directions in Section 2.

To answer an incoming firefighter's telephone call, follow the directions in Section 3.

Section 6 Lamp Test

Press and hold the LAMP TEST button to perform a lamp test of all the LEDs on the keypad, as well as the piezo.

Section 7 Periodic Testing and Maintenance

To ensure proper and reliable operation, system inspection and testing should be scheduled as required by the Authority Having Jurisdiction, or as required by NFPA 72 or local fire codes. A qualified Service Representative should perform testing.

Before Testing: Notify fire department and/or central alarm receiving station that testing will occur. Notify facility personnel of the test so alarm sounding devices are ignored during the test period.

After Testing: Notify all fire, central station, and/or building personnel when testing is complete.

Section 8 Local Service Representative:

NAME: _____

ADDRESS: _____

TELEPHONE NUMBER: _____

Manufacturer Warranties and Limitation of Liability

Manufacturer Warranties. Subject to the limitations set forth herein, Manufacturer warrants that the Products manufactured by it in its Northford, Connecticut facility and sold by it to its authorized Distributors shall be free, under normal use and service, from defects in material and workmanship for a period of thirty six months (36) months from the date of manufacture (effective Jan. 1, 2009). The Products manufactured and sold by Manufacturer are date stamped at the time of production. Manufacturer does not warrant Products that are not manufactured by it in its Northford, Connecticut facility but assigns to its Distributor, to the extent possible, any warranty offered by the manufacturer of such product. This warranty shall be void if a Product is altered, serviced or repaired by anyone other than Manufacturer or its authorized Distributors. This warranty shall also be void if there is a failure to maintain the Products and the systems in which they operate in proper working conditions.

MANUFACTURER MAKES NO FURTHER WARRANTIES, AND DISCLAIMS ANY AND ALL OTHER WARRANTIES, EITHER EXPRESSED OR IMPLIED, WITH RESPECT TO THE PRODUCTS, TRADEMARKS, PROGRAMS AND SERVICES RENDERED BY MANUFACTURER INCLUDING WITHOUT LIMITATION, INFRINGEMENT, TITLE, MERCHANTABILITY, OR FITNESS FOR ANY PARTICULAR PURPOSE. MANUFACTURER SHALL NOT BE LIABLE FOR ANY PERSONAL INJURY OR DEATH WHICH MAY ARISE IN THE COURSE OF, OR AS A RESULT OF, PERSONAL, COMMERCIAL OR INDUSTRIAL USES OF ITS PRODUCTS.

This document constitutes the only warranty made by Manufacturer with respect to its products and replaces all previous warranties and is the only warranty made by Manufacturer. No increase or alteration, written or verbal, of the obligation of this warranty is authorized. Manufacturer does not represent that its products will prevent any loss by fire or otherwise.

Warranty Claims. Manufacturer shall replace or repair, at Manufacturer's discretion, each part returned by its authorized Distributor and acknowledged by Manufacturer to be defective, provided that such part shall have been returned to Manufacturer with all charges prepaid and the authorized Distributor has completed Manufacturer's Return Material Authorization form. The replacement part shall come from Manufacturer's stock and may be new or refurbished. THE FOREGOING IS DISTRIBUTOR'S SOLE AND EXCLUSIVE REMEDY IN THE EVENT OF A WARRANTY CLAIM.

Warn-HL-08-2009.fm

NOTIFIER
12 Clintonville Road
Northford, CT 06472-1610 USA
203-484-7161
www.notifier.com

 **NOTIFIER**[®]
by Honeywell